



RX-V365

AV Receiver

OWNER'S MANUAL

Caution: Read this before operating your unit.

- 1 To assure the finest performance, please read this manual carefully. Keep it in a safe place for future reference.
- 2 Install this sound system in a well ventilated, cool, dry, clean place – away from direct sunlight, heat sources, vibration, dust, moisture, and/or cold. Allow ventilation space of at least 30 cm on the top, 20 cm on the left and right, and 20 cm on the back of this unit.
- 3 Locate this unit away from other electrical appliances, motors, or transformers to avoid humming sounds.
- 4 Do not expose this unit to sudden temperature changes from cold to hot, and do not locate this unit in an environment with high humidity (i.e. a room with a humidifier) to prevent condensation inside this unit, which may cause an electrical shock, fire, damage to this unit, and/or personal injury.
- 5 Avoid installing this unit where foreign objects may fall onto this unit and/or this unit may be exposed to liquid dripping or splashing. On the top of this unit, do not place:
 - Other components, as they may cause damage and/or discoloration on the surface of this unit.
 - Burning objects (i.e. candles), as they may cause fire, damage to this unit, and/or personal injury.
 - Containers with liquid in them, as they may fall and liquid may cause electrical shock to the user and/or damage to this unit.
- 6 Do not cover this unit with a newspaper, tablecloth, curtain, etc. in order not to obstruct heat radiation. If the temperature inside this unit rises, it may cause fire, damage to this unit, and/or personal injury.
- 7 Do not plug in this unit to a wall outlet until all connections are complete.
- 8 Do not operate this unit upside-down. It may overheat, possibly causing damage.
- 9 Do not use force on switches, knobs and/or cords.
- 10 When disconnecting the power cable from the wall outlet, grasp the plug; do not pull the cable.
- 11 Do not clean this unit with chemical solvents; this might damage the finish. Use a clean, dry cloth.
- 12 Only voltage specified on this unit must be used. Using this unit with a higher voltage than specified is dangerous and may cause fire, damage to this unit, and/or personal injury. Yamaha will not be held responsible for any damage resulting from use of this unit with a voltage other than specified.
- 13 To prevent damage by lightning, keep the power cord and outdoor antennas disconnected from a wall outlet or the unit during a lightning storm.
- 14 Do not attempt to modify or fix this unit. Contact qualified Yamaha service personnel when any service is needed. The cabinet should never be opened for any reasons.
- 15 When not planning to use this unit for long periods of time (i.e. vacation), disconnect the AC power plug from the wall outlet.
- 16 Install this unit near the AC outlet and where the AC power plug can be reached easily.
- 17 Be sure to read the “Troubleshooting” section on common operating errors before concluding that this unit is faulty.
- 18 Before moving this unit, press **Ⓐ STANDBY/ON** to set this unit in the standby mode, and disconnect the AC power plug from the wall outlet.
- 19 **VOLTAGE SELECTOR** (Asia and General models only)
The **VOLTAGE SELECTOR** on the rear panel of this unit must be set for your local main voltage **BEFORE** plugging into the AC wall outlet. Voltages are:
.....AC 110–120/220–240 V, 50/60 Hz
- 20 The batteries shall not be exposed to excessive heat such as sunshine, fire or like.
- 21 Excessive sound pressure from earphones and headphones can cause hearing loss.
- 22 When replacing the batteries, be sure to use batteries of the same type. Danger of explosion may happen if batteries are incorrectly replaced.

WARNING

TO REDUCE THE RISK OF FIRE OR ELECTRIC SHOCK, DO NOT EXPOSE THIS UNIT TO RAIN OR MOISTURE.

As long as this unit is connected to the AC wall outlet, it is not disconnected from the AC power source even if you turn off this unit by **Ⓐ STANDBY/ON**. In this state, this unit is designed to consume a very small quantity of power.

■ For U.K. customers

If the socket outlets in the home are not suitable for the plug supplied with this appliance, it should be cut off and an appropriate 3 pin plug fitted. For details, refer to the instructions described below.

Note

The plug severed from the mains lead must be destroyed, as a plug with bared flexible cord is hazardous if engaged in a live socket outlet.

■ Special Instructions for U.K. Model

IMPORTANT

THE WIRES IN MAINS LEAD ARE COLOURED IN ACCORDANCE WITH THE FOLLOWING CODE:

Blue: NEUTRAL

Brown: LIVE

As the colours of the wires in the mains lead of this apparatus may not correspond with the coloured markings identifying the terminals in your plug, proceed as follows:

The wire which is coloured BLUE must be connected to the terminal which is marked with the letter N or coloured BLACK. The wire which is coloured BROWN must be connected to the terminal which is marked with the letter L or coloured RED.

Making sure that neither core is connected to the earth terminal of the three pin plug.



Information for Users on Collection and Disposal of Old Equipment and used Batteries

These symbols on the products, packaging, and/or accompanying documents mean that used electrical and electronic products and batteries should not be mixed with general household waste.

For proper treatment, recovery and recycling of old products and used batteries, please take them to applicable collection points, in accordance with your national legislation and the Directives 2002/96/EC and 2006/66/EC.

By disposing of these products and batteries correctly, you will help to save valuable resources and prevent any potential negative effects on human health and the environment which could otherwise arise from inappropriate waste handling.

For more information about collection and recycling of old products and batteries, please contact your local municipality, your waste disposal service or the point of sale where you purchased the items.

[Information on Disposal in other Countries outside the European Union]

These symbols are only valid in the European Union. If you wish to discard these items, please contact your local authorities or dealer and ask for the correct method of disposal.

Note for the battery symbol (bottom two symbol examples):

This symbol might be used in combination with a chemical symbol. In this case it complies with the requirement set by the Directive for the chemical involved.



Pb

Limited Guarantee for European Economic Area (EEA) and Switzerland

Thank you for having chosen a Yamaha product. In the unlikely event that your Yamaha product needs guarantee service, please contact the dealer from whom it was purchased. If you experience any difficulty, please contact Yamaha representative office in your country. You can find full details on our website (<http://www.yamaha-hifi.com/> or <http://www.yamaha-uk.com/> for U.K. resident).

The product is guaranteed to be free from defects in workmanship or materials for a period of two years from the date of the original purchase. Yamaha undertakes, subject to the conditions listed below, to have the faulty product or any part(s) repaired, or replaced at Yamaha's discretion, without any charge for parts or labour. Yamaha reserves the right to replace a product with that of a similar kind and/or value and condition, where a model has been discontinued or is considered uneconomic to repair.

Conditions

1. The original invoice or sales receipt (showing date of purchase, product code and dealer's name) MUST accompany the defective product, along with a statement detailing the fault. In the absence of this clear proof of purchase, Yamaha reserves the right to refuse to provide free of charge service and the product may be returned at the customer's expense.
2. The product MUST have been purchased from an AUTHORISED Yamaha dealer within the European Economic Area (EEA) or Switzerland.
3. The product must not have been the subject of any modifications or alterations, unless authorised in writing by Yamaha.
4. The following are excluded from this guarantee:
 - a. Periodic maintenance and repair or replacement of parts due to normal wear and tear.
 - b. Damage resulting from:
 - (1) Repairs performed by the customer himself or by an unauthorised third party.
 - (2) Inadequate packaging or mishandling, when the product is in transit from the customer. Please note that it is the customer's responsibility to ensure the product is adequately packaged when returning the product for repair.
 - (3) Misuse, including but not limited to (a) failure to use the product for its normal purpose or in accordance with Yamaha's instructions on the proper use, maintenance and storage, and (b) installation or use of the product in a manner inconsistent with the technical or safety standards in force in the country where it is used.
 - (4) Accidents, lightning, water, fire, improper ventilation, battery leakage or any cause beyond Yamaha's control.
 - (5) Defects of the system into which this product is incorporated and/or incompatibility with third party products.
 - (6) Use of a product imported into the EEA and/or Switzerland, not by Yamaha, where that product does not conform to the technical or safety standards of the country of use and/or to the standard specification of a product sold by Yamaha in the EEA and/or Switzerland.
 - (7) Non AV (Audio Visual) related products.
(Products subject to "Yamaha AV Guarantee Statement" are defined in our website at <http://www.yamaha-hifi.com/> or <http://www.yamaha-uk.com/> for U.K. resident.)
5. Where the guarantee differs between the country of purchase and the country of use of the product, the guarantee of the country of use shall apply.
6. Yamaha may not be held responsible for any losses or damages, whether direct, consequential or otherwise, save for the repair or replacement of the product.
7. Please backup any custom settings or data, as Yamaha may not be held responsible for any alteration or loss to such settings or data.
8. This guarantee does not affect the consumer's statutory rights under applicable national laws in force or the consumer's rights against the dealer arising from their sales/purchase contract.

Contents

INTRODUCTION

PREPARATION

BASIC OPERATION

ADVANCED OPERATION

ADDITIONAL INFORMATION

English

INTRODUCTION

Features	2
Supplied accessories	2
Functional overview	3
Front panel	3
Front panel display.....	4
Remote control.....	5
Rear panel	6
Quick start guide	7

PREPARATION

Preparation of remote control	8
Connections	9
Placing speakers.....	9
Connecting speakers	9
Connecting video components.....	11
Connecting other components	13
Using the VIDEO AUX jacks on the front panel	14
Connecting the FM and AM antennas	15
Connecting the power cable.....	15
Turning on and off the power	15
Optimizing the speaker setting for your listening room (YPAO)	16
Using AUTO SETUP.....	16

BASIC OPERATION

Playback	18
Basic procedure.....	18
Additional operations.....	19
Selecting the SCENE templates	22
Selecting the desired SCENE template.....	22
Creating your original SCENE templates	24
Sound field programs	25
Selecting sound field programs.....	25
FM/AM tuning	27
Overview.....	27
FM/AM tuning operations	27
Preset FM/AM stations	27
Radio Data System tuning (Europe and Russia models only)	29
Displaying the Radio Data System information	29
Selecting the Radio Data System program type (PTY SEEK mode).....	29
Using the enhanced other networks (EON) data service.....	30

ADVANCED OPERATION

Set menu	31
Using set menu.....	32
1 SOUND MENU	32
2 INPUT MENU	34
3 OPTION MENU	35
Advanced setup	37

ADDITIONAL INFORMATION

Troubleshooting	38
Glossary	43
Specifications	44
Index	45

About this manual

- * indicates a tip for your operation.
- Some operations can be performed by using either the buttons on the front panel or the ones on the remote control. In case the button names differ between the front panel and the remote control, the button name on the remote control is given in parentheses.
- This manual is printed prior to production. Design and specifications are subject to change in part as a result of improvements, etc. In case of differences between the manual and product, the product has priority.
- “**STANDBY/ON**” or “**DVD**” (example) indicates the name of the parts on the front panel or the remote control. Refer to the “Functional overview” on page 3.

INTRODUCTION

Features

Built-in 5-channel power amplifier

- ◆ Minimum RMS output power (1 kHz, 0.9% THD, 6 Ω)
Front: 100 W/ch
Center: 100 W
Surround: 100 W/ch

Various input/output connectors

- ◆ HDMI (IN x 2, OUT x 1), Component video (IN x 3, OUT x 1), Composite video (IN x 3, OUT x 2), Coaxial digital audio (IN x 1), Optical digital audio (IN x 2), Analog audio (IN x 9, OUT x 2)
- ◆ Speaker out (5-channel), Subwoofer out
- ◆ Discrete multi-channel input (6-channel)

SCENE select function

- ◆ Preset SCENE templates for various situations
- ◆ SCENE template customizing capability

Sound field programs

- ◆ Proprietary Yamaha technology for the creation of surround field
- ◆ Compressed Music Enhancer mode
- ◆ SILENT CINEMA™

Decoders and DSP circuits

- ◆ Dolby Digital decoder
- ◆ Dolby Pro Logic/Dolby Pro Logic II decoder
- ◆ DTS decoder
- ◆ Virtual CINEMA DSP
- ◆ SILENT CINEMA™

Sophisticated FM/AM tuner

- ◆ 40-station random and direct preset tuning
- ◆ Automatic preset tuning

HDMI™ (High-Definition Multimedia Interface)

- ◆ HDMI interface for standard, enhanced or high-definition video (includes 1080p video signal transmission)

Other features

- ◆ 192-kHz/24-bit D/A converter
- ◆ Sleep timer
- ◆ Cinema and music night listening modes
- ◆ Remote control capability



Manufactured under license from Dolby Laboratories. "Dolby," "Pro Logic," and the double-D symbol are trademarks of Dolby Laboratories.



Manufactured under license under U.S. Patent No's: 5,451,942;5,956,674;5,974,380;5,978,762;6,487,535 and other U.S. and worldwide patents issued and pending. DTS is a registered trademark and the DTS logos and symbol are trademarks of DTS, Inc. © 1996-2007 DTS, Inc. All Rights Reserved.

HDMI

"HDMI," the "HDMI" logo and "High-Definition Multimedia Interface" are trademarks, or registered trademarks of HDMI Licensing LLC.

SILENT™
CINEMA

"SILENT CINEMA" is a trademark of Yamaha Corporation.

Supplied accessories

Check that you received all of the following parts.

- Remote control
- Batteries (2) (AAA, R03, UM-4)
- AM loop antenna
- Indoor FM antenna
- Optimizer microphone

Functional overview

Front panel

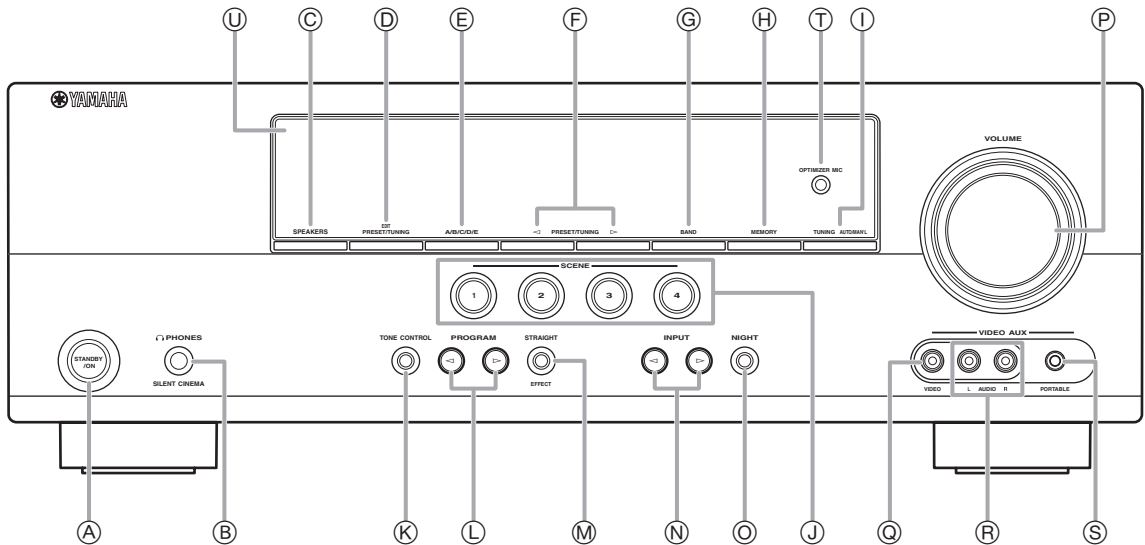

- (A) STANDBY/ON**
Turns on this unit, or sets it to standby mode (see page 15).
- (B) PHONES jack**
Connect to a pair of headphones (see page 20).
- (C) SPEAKERS**
Turns on or off the set of front speakers connected to the FRONT A or FRONT B speaker terminals (see page 19).
- (D) EDIT PRESET/TUNING**
Switches the tuning mode (see page 27).
- (E) A/B/C/D/E**
Selects the preset station group (A to E) (see page 28).
- (F) PRESET/TUNING </>/>**
Tunes into radio stations manually or automatically and selects a preset station group (see page 27).
- (G) BAND**
Selects the reception band from FM and AM (see page 27).
- (H) MEMORY**
Stores a station that you tuned into as a preset station (see page 27).
- (I) TUNING AUTO/MAN'L**
Selects a tuning method from automatic or manual tuning (see page 27).
- (J) SCENE 1/2/3/4**
Recalls an input source and a sound field program assigned to each SCENE button (see page 22).
- (K) TONE CONTROL**
Selects "BASS" and "TREBLE" to adjust frequency response (see page 20).
- (L) PROGRAM </>/>**
Selects a sound field program (see page 25).
- (M) STRAIGHT**
Activates the "STRAIGHT" mode (see page 26).
- (N) INPUT </>/>**
Selects an input source (see page 18).
- (O) NIGHT**
Selects a night listening mode (see page 20).
- (P) VOLUME control**
Adjusts the volume level of this unit (see page 18).
- (Q) VIDEO (VIDEO AUX) jack**
Connects to a game console or a video camera using a composite video cable (see page 14).
- (R) AUDIO L/R (VIDEO AUX) jacks**
Connects to a game console or a video camera using analog audio cables (see page 14).
- (S) PORTABLE (VIDEO AUX) jack**
Connects to an audio component (such as iPod) (see page 14).
- (T) OPTIMIZER MIC jack**
Connect to the supplied optimizer microphone (see page 16).
- (U) Front panel display**
Shows information about the operational status of this unit (see page 18).

Front panel display

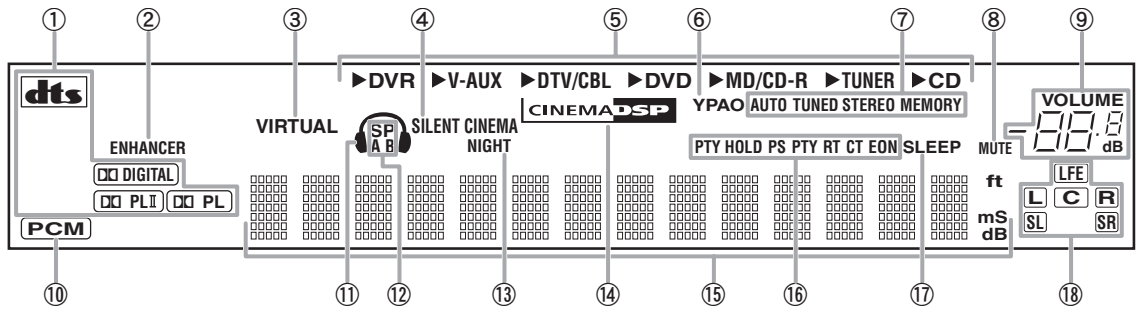

- ① **Decoder indicator**
Lights up when any of the decoders of this unit functions.
- ② **ENHANCER indicator**
Lights up when the Compressed Music Enhancer mode is selected (see page 25).
- ③ **VIRTUAL indicator**
Lights up when Virtual CINEMA DSP is active (see page 26).
- ④ **SILENT CINEMA indicator**
Lights up when headphones are connected and a sound field program is selected (see page 26).
- ⑤ **Input source indicators**
The corresponding cursor lights up to show the currently selected input source.
- ⑥ **YPAO indicator**
Lights up when you run "AUTO SETUP" and when the speaker settings set in "AUTO SETUP" are used without any modifications (see page 16).
- ⑦ **Tuner indicators**
Lights up when this unit is in the FM or AM tuning mode (see page 27).
- ⑧ **MUTE indicator**
Flashes while the MUTE function is on (see page 20).
- ⑨ **VOLUME level indicator**
Indicates the current volume level.
- ⑩ **PCM indicator**
Lights up when this unit is reproducing PCM (Pulse Code Modulation) digital audio signals.
- ⑪ **Headphones indicator**
Lights up when headphones are connected (see page 20).
- ⑫ **SP A B indicators**
Lights up according to the set of front speakers selected (see page 18).
- ⑬ **NIGHT indicator**
Lights up when you select a night listening mode (see page 20).
- ⑭ **CINEMA DSP indicator**
Lights up when you select a sound filed program (see page 26).
- ⑮ **Multi-information display**
Shows the name of the current sound field program and other information when adjusting or changing settings.
- ⑯ **Radio Data System indicators (Europe and Russia models only)**
 - **PTY HOLD**
Lights up when this unit is in the PTY SEEK mode (see page 29).
 - **PS, PTY, RT and CT**
Light up according to the available Radio Data System information.
 - **EON**
Lights up when the EON data service is available.
- ⑰ **SLEEP indicator**
Lights up while the sleep timer is on (see page 21).
- ⑱ **Input channel and speaker indicators**
 - **LFE indicator**
Lights up when the input signal contains the LFE signal.
 - **Input channel indicators**
Indicates the channel components of the current digital input signal.

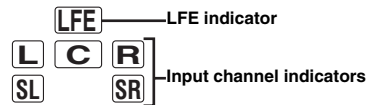

Remote control

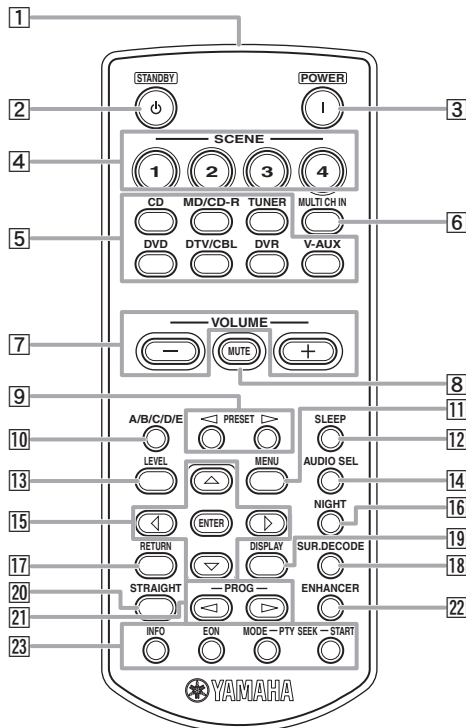

- 1 Infrared window**
Outputs infrared control signals (see page 8).
- 2 STANDBY (⏻)**
Sets this unit to the standby mode (see page 15).
- 3 POWER (⏻)**
Turns this unit on (see page 15).
- 4 SCENE 1/2/3/4**
Recalls an input source and a sound field program assigned to each SCENE button (see page 22).
- 5 Input selector buttons**
Switches the input source to each source (see page 18).
- 6 MULTI CH IN**
Sets the input source to MULTI CH IN (see page 19).
- 7 VOLUME +/-**
Adjusts the volume level of this unit (see page 18).
- 8 MUTE**
Mutes audio output. Press the button again to resume audio output (see page 20).
- 9 PRESET </>**
Tunes into radio stations manually or automatically and selects a Preset station number (1 to 8) (see page 27).
- 10 A/B/C/D/E**
Selects the preset station group (A to E) (see page 28).
- 11 MENU**
Displays the set menu on the front panel display (see page 32).
- 12 SLEEP**
Sets the sleep timer (see page 21).
- 13 LEVEL**
Selects the speaker that you want to adjust (see page 20).

- 14 AUDIO SEL**
Selects an audio input select setting for each input source (see page 19).
- 15 Cursors (</> / ▽ / △) / ENTER**
 - Press cursors to navigate the set menu (see page 32).
 - Press ENTER to confirm a selection in the set menu (see page 32).
- 16 NIGHT**
Selects a night listening mode (see page 20).
- 17 RETURN**
Returns the previous menu level in the set menu mode (see page 32).
- 18 SUR.DECODE**
Selects a decoder from four decoders (see page 26).
- 19 DISPLAY**
Is not available for this unit.
- 20 STRAIGHT**
Activates the “STRAIGHT” mode (see page 26).
- 21 PROG </>**
Selects the sound field program (see page 25).
- 22 ENHANCER**
Sets the sound field program to the “Music Enh. 2ch” or “Music Enh. 5ch” (see page 25).
- 23 INFO/Radio data system control**
Controls the Radio Data System with 4-buttons (INFO/EON/ MODE (PTY-SEEK)/START (PTY-SEEK)) (see page 29).

Rear panel

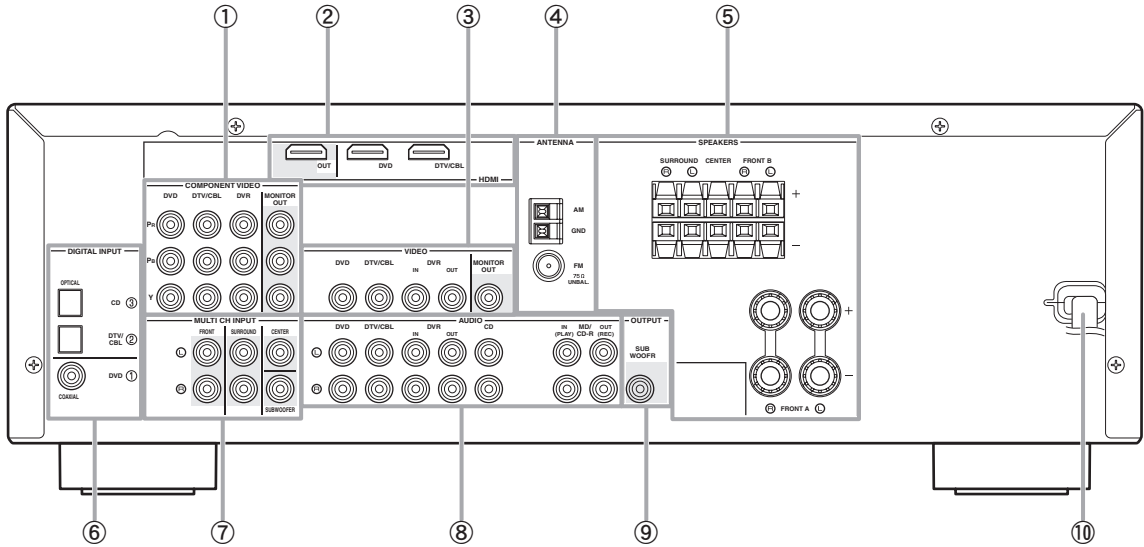

① COMPONENT VIDEO jacks

Connect to Y, PB/CB and PR/CR jacks on your video components with component video cables (see page 11).

- DVD input jacks
- DTV/CBL input jacks
- DVR input jacks
- MONITOR OUT output jacks

② HDMI terminals

Connect to HDMI output/input terminals on your external components with HDMI cables (see page 11).

- HDMI DVD terminal
- HDMI DTV/CBL terminal
- HDMI OUT output terminal

③ VIDEO jacks

Connect to video jacks on your video components with composite video cables (see page 11).

- DVD input jack
- DTV/CBL input jack
- DVR IN jack
- DVR OUT jack
- MONITOR OUT jack

④ ANTENNA terminals

Connect to the supplied FM and AM antennas (see page 15).

⑤ SPEAKERS terminals

Connect to each speakers (see page 9).

- FRONT A L/R
- FRONT B L/R
- SURROUND L/R
- CENTER

⑥ DIGITAL INPUT jacks

Connect to the DIGITAL output jacks on your digital audio components with Coaxial/Optical digital audio cables. This input jacks support PCM, Dolby Digital and DTS bitstream (see page 11).

- COAXIAL (DVD)
- OPTICAL (DTV/CBL)
- OPTICAL (CD)

⑦ MULTI CH INPUT jacks

Connect to the output jacks on your multi-format player or external decoder with analog audio cables (see page 14).

- FRONT L/R jack
- SURROUND L/R jack
- CENTER jack
- SUBWOOFER jack

⑧ AUDIO jacks

Connect to the audio output/input jacks on your components with analog audio cables (see page 11).

- DVD L/R jack
- DTV/CBL L/R jack
- DVR IN L/R jack
- DVR OUT L/R jack
- CD L/R jack
- IN (PLAY) L/R jack
- OUT (REC) L/R jack

⑨ SUBWOOFER OUTPUT jack

Connect to a Subwoofer with an analog audio cable (see page 9).

⑩ Power cable

Connect to a standard AC outlet (see page 15).

Quick start guide

The following steps describe the easiest way to operate this unit. See the related pages for details on the operation and settings.

Step 1: Check the items

In these steps, you need the following items which are not included in the package of this unit.

❑ Speakers

We recommend magnetically shielded speakers.

- ❑ **Front speaker** x 2
At least two front speakers are required to start playback.
- ❑ **Center speaker** x 1
- ❑ **Surround speaker** x 2
- ❑ **Active subwoofer** x 1
Select an active subwoofer equipped with an RCA input jack.
- ❑ **Speaker cable** x 5
- ❑ **Subwoofer cable** x 1
Select a monaural RCA cable.
- ❑ **DVD player** x 1
Select DVD player equipped with coaxial digital audio output jack and composite video output jack.
- ❑ **Video monitor** x 1
Select a TV monitor, video monitor or projector equipped with a composite video input jack.
- ❑ **Video cable** x 2
Select an RCA composite video cable.
- ❑ **Digital coaxial audio cable** x 1

Step 2: Set up your speakers

Place your speakers in the room and connect them to this unit.

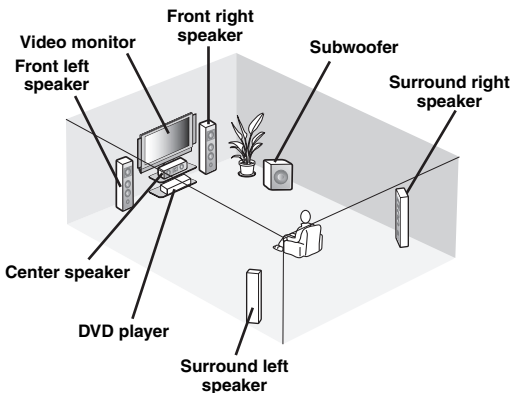

- Placing speakers P. 9
- Connecting speakers P. 9

Step 3: Connect your components

Connect your TV, DVD player or other components.

- Connecting a TV monitor or projector P. 12
- Connecting audio and video components P. 13
- Connecting a multi-format player or an external decoder P. 14
- Using the VIDEO AUX jacks on the front panel P. 14
- Connecting the FM and AM antennas P. 15

Step 4: Turn on the power

Connect the power cable and turn on this unit.

- Connecting the power cable P. 15
- Turning on and off the power P. 15

Step 5: Select the input source and start playback

Select the component connected in the step 3 as an input source and start playback.

- Basic procedure P. 18
- Selecting the SCENE templates P. 22
- Adjusting the sound field programs P. 25

PREPARATION

Preparation of remote control

Installing batteries in the remote control

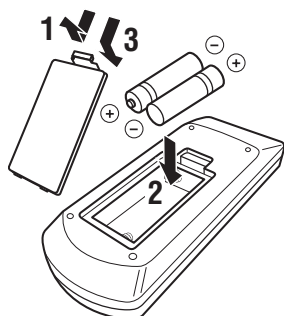

- 1 Take off the battery compartment cover.**
- 2 Insert the four supplied batteries (AAA, R03, UM-4) according to the polarity markings (+ and -) on the inside of the battery compartment.**
- 3 Snap the battery compartment cover back into place.**

Notes

- Change all of the batteries if you notice the following conditions:
 - the operation range of the remote control decreases.
- Do not use old batteries together with new ones.
- Do not use different types of batteries (such as alkaline and manganese batteries) together. Read the packaging carefully as these different types of batteries may have the same shape and color.
- If the batteries have leaked, dispose of them immediately. Avoid touching the leaked material or letting it come into contact with clothing, etc. Clean the battery compartment thoroughly before installing new batteries.
- Do not throw away batteries with general house waste; dispose of them correctly in accordance with your local regulations.

Using the remote control

The remote control transmits a directional infrared ray. Be sure to aim the remote control directly at the remote control sensor on this unit during operation.

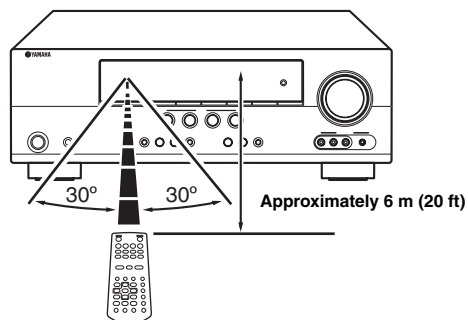

1 Infrared window

Outputs infrared control signals. Aim this window at the component you want to operate.

Notes

- Do not spill water or other liquids on the remote control.
- Do not drop the remote control.
- Do not leave or store the remote control in the following types of conditions:
 - places of high humidity, such as near a bath
 - places of high temperature, such as near a heater or stove
 - places of extremely low temperatures
 - dusty places

Connections

Placing speakers

The speaker layout below shows the speaker setting we recommend. You can use it to enjoy CINEMA DSP and multi-channel audio sources.

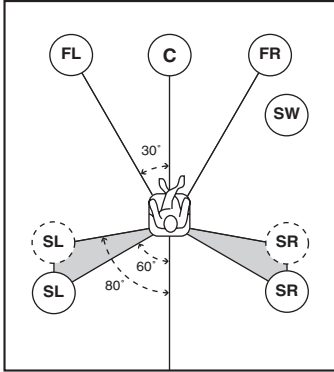

Front left and right speakers (FL and FR)

The front speakers are used for the main source sound plus effect sounds. Place these speakers at an equal distance from the ideal listening position. The distance of each speaker from each side of the video monitor should be the same.

Center speaker (C)

The center speaker is for the center channel sounds (dialog, vocals, etc.). If for some reason it is not practical to use a center speaker, you can do without it. Best results, however, are obtained with the full system.

Surround left and right speakers (SL and SR)

The surround speakers are used for effect and surround sounds.

Subwoofer (SW)

The use of a subwoofer with a built-in amplifier, such as the Yamaha Active Servo Processing Subwoofer System, is effective not only for reinforcing bass frequencies from any or all channels, but also for high fidelity sound reproduction of the LFE (low-frequency effect) channel included in Dolby Digital and DTS sources. The position of the subwoofer is not so critical, because low bass sounds are not highly directional. But it is better to place the subwoofer near the front speakers. Turn it slightly toward the center of the room to reduce wall reflections.

Connecting speakers

Be sure to connect the left channel (L), right channel (R), “+” (red) and “-” (black) properly. If the connections are faulty, this unit cannot reproduce the input sources accurately.

Caution

- Use speakers with the specified impedance shown on the rear panel of this unit.
- Before connecting the speakers, make sure that this the AC power plug is disconnected from the AC wall outlet.
- Do not let the bare speakers wires touch each other or do not let them touch any metal part of this unit. This could damage this unit and/or speakers.
- Use magnetically shielded speakers. If this type of speaker still creates interference with the monitor, place the speakers away from the monitor.

■ 5.1-channel speaker connection

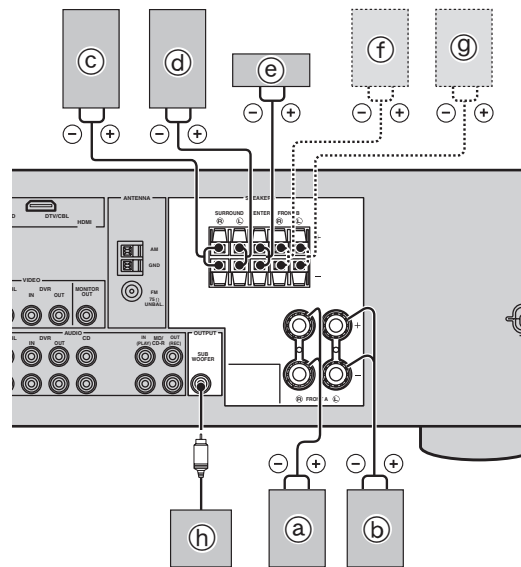

Speakers	Jacks on this unit
(a) Front speaker (A) Right*	FRONT A (R)
(b) Front speaker (A) Left*	FRONT A (L)
(c) Surround speaker Right	SURROUND (R)
(d) Surround speaker Left	SURROUND (L)
(e) Center speaker	CENTER
(f) Front speaker (B) Right*	FRONT B (R)
(g) Front speaker (B) Left*	FRONT B (L)
(h) Subwoofer	SUBWOOFER

* You can select the front speaker set from Front speakers (A) and Front speakers (B) by pressing **ⓈPEAKERS** repeatedly. See page 19 for details.

■ **Connect speaker cables to each speaker**

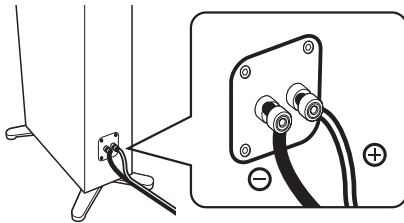

Cables are colored or shaped differently, perhaps with a stripe, groove or ridge. Connect the striped (grooved, etc.) cable to the “+” (red) terminals of your speaker. Connect the plain cable to the “-” (black) terminals.

■ **Before connecting to the SPEAKERS terminal**

A speaker cord is actually a pair of insulated cables running side by side.

Remove approximately 10 mm (3/8”) of insulation from the end of each speaker cable and then twist the bare wires of the cable together to prevent short circuits.

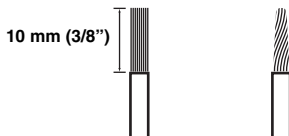

■ **Connecting to the FRONT A terminals**

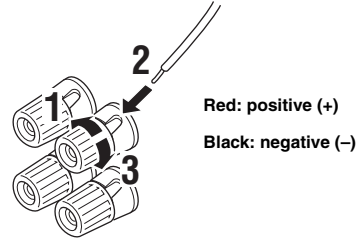

- 1 Loosen the knob.
- 2 Insert the bare end of the speaker wire into the slit on the terminal.
- 3 Tighten the knob to secure the wire.

■ **Connecting to the FRONT B, CENTER, and SURROUND terminals**

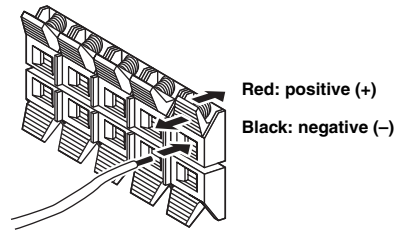

- 1 Press down the tab.
- 2 Insert the bare end of the speaker wire into the hole on the terminal.
- 3 Release the tab to secure the wire.

Connecting video components

Information on jacks and cable plugs

Audio jacks and cable plugs

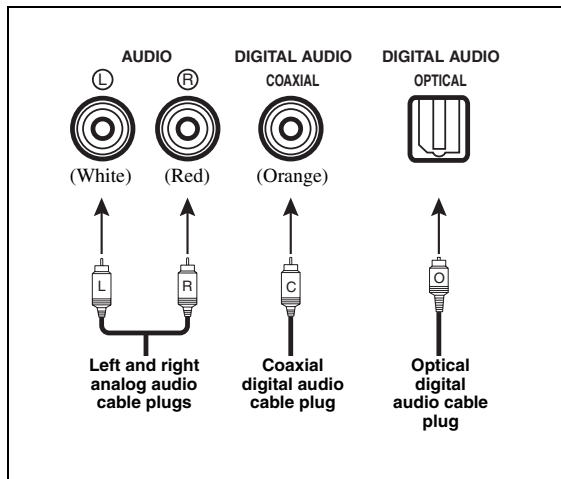

AUDIO jacks

For conventional analog audio signals transmitted via left and right analog audio cables. Connect red plugs to the right jacks and white plugs to the left jacks.

COAXIAL jack

For digital audio signals transmitted via coaxial digital audio cable.

OPTICAL jacks

For digital audio signals transmitted via optical digital audio cables.

Notes

- You can use the digital jacks to input PCM, Dolby Digital, and DTS bitstreams. All digital input jacks are compatible with digital signals with up to 96 kHz of sampling frequency.
- This unit handles digital and analog signals independently. Thus audio signals input at the digital jacks are not output at the analog AUDIO OUT (REC) jack.

Video jacks and cable plugs

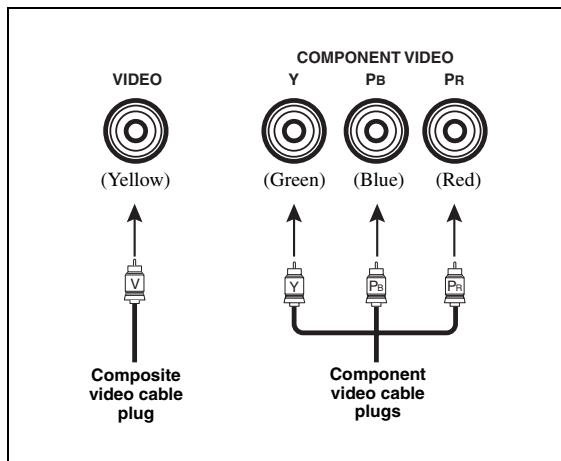

VIDEO jacks

For conventional composite video signals transmitted via composite video cables.

COMPONENT VIDEO jacks

For component signals, separated into the luminance (Y) and chrominance (PB, PR) video signals transmitted on separate wires of component video cables.

Video signal flow for MONITOR OUT

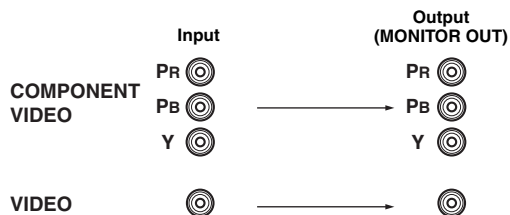

Information on HDMI™

Audio signals input at the HDMI jack are not output from any speaker terminals but output from the connected video monitor. To enjoy the sound from speakers connected to this unit,

- make an analog or digital connection besides the HDMI connection (see page 13).
- mute the volume of the connected video monitor.

You can play back pictures by connecting your video monitor and video source component to this unit using HDMI connections.

At that time, audio/video signals output from the connected component (such as DVD player etc.) are output to the connected video monitor only when this unit is turned on and set to the input source (DVD or DTV/CBL).

Furthermore, available audio/video signals depend on the specification of the connected video monitor. Refer to the instruction manual of each connected component.

HDMI jack and cable plug

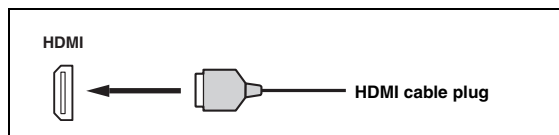

- We recommend using an HDMI cable shorter than 5 meters (16 feet) with the HDMI logo printed on it.
- Use a conversion cable (HDMI jack ↔ DVI-D jack) to connect this unit to other DVI components.

Using the AUDIO OUT REC jack

You can record the audio signal output at the AUDIO OUT (REC) jack by using the recording components.

Note

- Check the copyright laws in your country to record from CDs, radio, etc. Recording of copyrighted material may infringe copyright laws.

Connecting a TV monitor or projector



Make sure that this unit and other components are unplugged from the AC wall outlets.

Note

- If you turn off the video monitor connected to the HDMI OUT jack via a DVI connection, the connection may fail. In this case, the HDMI indicator flashes irregularly.

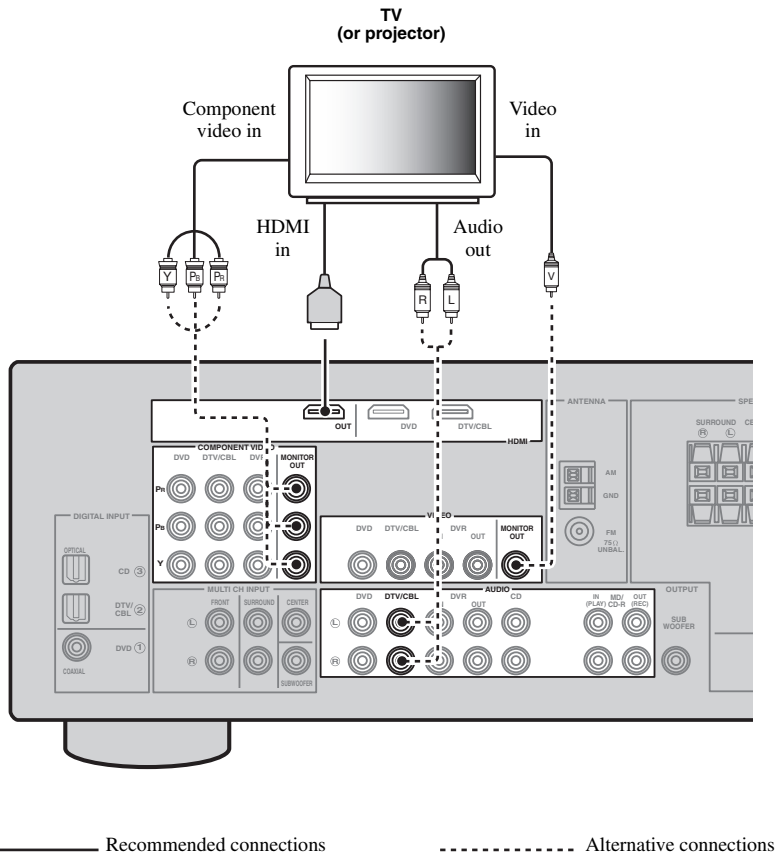

Connecting other components

Connecting audio and video components

This unit has three types of audio jacks, two types of video jacks and HDMI jacks. You can choose the connection method depending on the component to be connected.

■ Connecting example (connecting a DVD player)

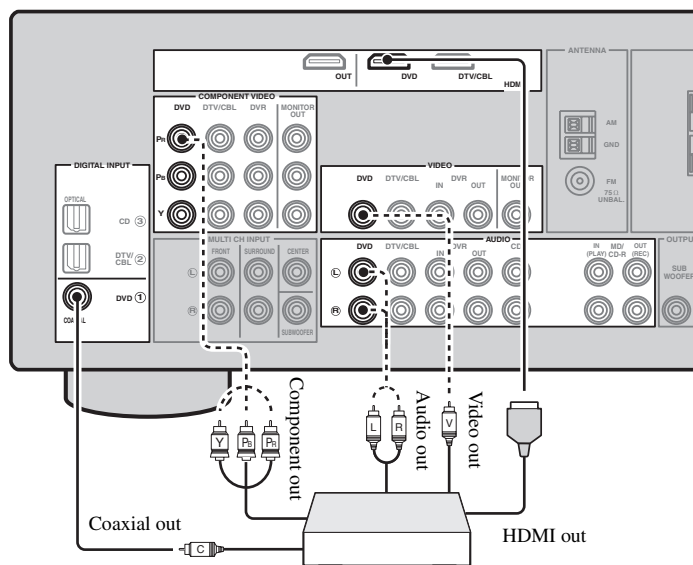

————— Recommended connections - - - - - Alternative connections

■ Jacks used for audio and video connections

Recommended connections are indicated by (*). When connecting a recording component, you need to make additional connections for recording (signal transmission from this unit to the recording component).



Make sure that this unit and other components are unplugged from the AC wall outlets.

- 💡 You can also use the VIDEO AUX jacks (see page 14) on the front panel to connect an additional component.
- To confirm the positions of “jacks on this unit” in the following table, refer to “Rear panel” in “Functional overview” on page 6.

Component	Signal type	Jacks on component	Jacks on this unit
DVD player or Blu-ray Disc player	Video	HDMI out*	HDMI (DVD)*
		Component out	COMPONENT VIDEO (DVD)
		Video out (composite)	VIDEO (DVD)
	Audio	Optical out*	COAXIAL (DVD)*
Audio out (analog)		AUDIO (DVD)	
Set-top box	Video	HDMI out*	HDMI (DTV/CBL)*
		Component out	COMPONENT VIDEO (DTV/CBL)
		Video out (composite)	VIDEO (DTV/CBL)
	Audio	Optical out*	OPTICAL (DTV/CBL)*
		Analog out (analog)	AUDIO (DTV/CBL)

Component	Signal type	Jacks on component	Jacks on this unit
DVD recorder	Video	HDMI out*	HDMI (DVR)*
		Video out (composite)	VIDEO (DVR IN)
	Audio	Audio out (analog)*	AUDIO (IN (PLAY))*
	Audio recording	Audio in (analog)*	AUDIO (OUT (REC))*
	Video recording	Video in (composite)*	VIDEO (DVR OUT)*
	CD player	Coaxial out*	OPTICAL (CD)*
Audio out (analog)		AUDIO (CD)	
MD or CD recorder	Audio	Audio out (analog)*	AUDIO (IN (PLAY))*
	Audio recording	Audio in (analog)*	AUDIO (OUT (REC))*

Notes

- Be sure to make the same type of video connections as those made for your TV if the video conversion is disabled. For example, if you connected your TV to the VIDEO MONITOR OUT jack of this unit, connect other components to the VIDEO jacks.
- Check the copyright laws in your country to record from CDs, radio, etc. Recording of copyrighted material may infringe copyright laws.
- To make a digital connection to a component other than the default one assigned to each DIGITAL INPUT or DIGITAL OUTPUT jack, configure the "INPUT ASSIGN" setting (see page 34).
- Only analog audio signals output at AUDIO OUT (REC) jack can be recorded using the recording components. Therefore Digital signals input at the DIGITAL INPUT jacks or analog signals input at MULTI CH IN jacks can be output at the analog AUDIO OUT (REC) jack for recording.

Connecting a multi-format player or an external decoder

This unit is equipped with 6 additional input jacks (FRONT L/R, SURROUND L/R, CENTER and SUBWOOFER) for discrete multi-channel input from a multi-format player, external decoder or sound processor. Connect the output jacks on your multi-format player or external decoder to the MULTI CH INPUT jacks. Be sure to match the left and right output jacks to the left and right input jacks for the front and surround channels.

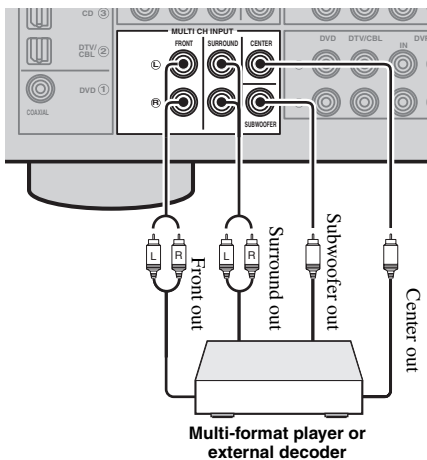

Notes

- When you select the component connected to the MULTI CH INPUT jacks as the input source (see page 19), this unit automatically turns off the digital sound field processor, and you cannot select sound field programs.
- This unit does not redirect signals input at the MULTI CH INPUT jacks to accommodate for missing speakers. We recommend that you connect a 5.1-channel speaker system before using this feature.
- The source connected to the MULTI CH INPUT jacks on this unit cannot be recorded.

Using the VIDEO AUX jacks on the front panel

Use the VIDEO AUX jacks on the front panel to connect a game console or a video camera to this unit. To reproduce the source signals input at these jacks, select "V-AUX" as the input source.

Caution

Be sure to turn down the volume of this unit and other components before making connections.

Note

- The audio signals input at the PORTABLE mini jack take priority over the ones input at the AUDIO L/R jacks.

Connecting the FM and AM antennas

Both FM and AM indoor antennas are supplied with this unit. In general, these antennas should provide sufficient signal strength. Connect each antenna correctly to the designated terminals.

Notes

- The AM loop antenna should be placed away from this unit.
- A properly installed outdoor antenna provides clearer reception than an indoor one. If you experience poor reception quality, install an outdoor antenna. Consult the nearest authorized Yamaha dealer or service center about outdoor antennas.
- The AM loop antenna should always be connected, even if an outdoor AM antenna is connected to this unit.

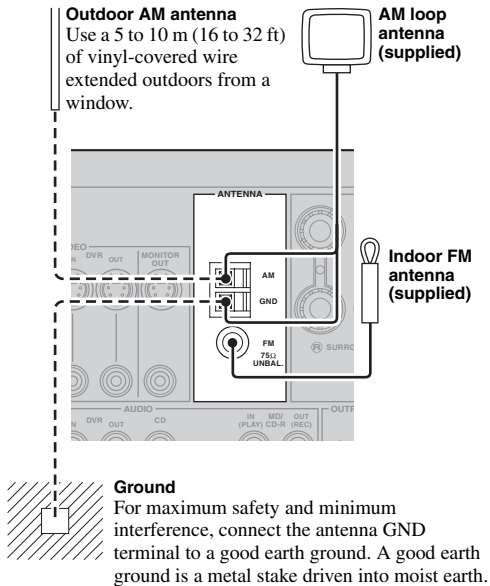

Connecting the wire of the AM loop antenna

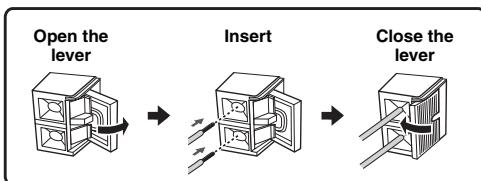

Assembling the supplied AM loop antenna

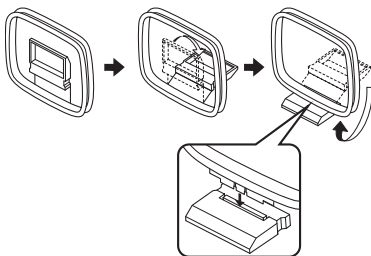

Note

- The types of the supplied AM loop antenna is different depending on the models.

Connecting the power cable

Once all connections are complete, plug the power cable into the AC wall outlet.

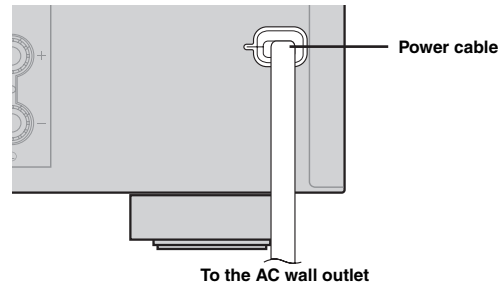

Turning on and off the power

Turning on this unit

Press **(A) STANDBY/ON** (or **(3) POWER**) to turn on this unit.



- When you turn on this unit, there will be a 4 to 5-second delay before this unit can reproduce sound.

Set this unit to the standby mode

Press **(A) STANDBY/ON** (or **(2) STANDBY**) to turn off this unit.

Note

- In the standby mode, this unit consumes a small amount of power in order to receive infrared signals from the remote control.

Optimizing the speaker setting for your listening room (YPAO)

This unit has the Yamaha Parametric Acoustic Optimizer (YPAO). With the YPAO, this unit automatically adjusts output characteristics of your speakers based on speaker positions, speaker performances, and acoustic characteristics of the room. We recommend that you first adjust the output characteristics with the YPAO when you use this unit.

Notes

- Be advised that it is normal for loud test tones to be output during the “AUTO SETUP” procedure. Do not allow small children to enter the room during the procedure.
- To achieve the best results, make sure that the room is as quiet as possible while the “AUTO SETUP” procedure is in progress. If there is too much ambient noise, the results may not be satisfactory.

Using AUTO SETUP



- Initial settings are indicated by (*) in the following each parameter.

1 Make sure of the following check points.

Before starting the automatic setup, check the following check points.

- All speakers and subwoofer are connected appropriately.
- Headphones are disconnected from this unit.
- This unit is turned on.
- The connected subwoofer is tuned on and the volume level is set to about half way (or slightly less).
- FRONT A speakers are selected as the front speaker system (see page 19).
- The room is sufficiently quiet.
- The crossover frequency control of the connected subwoofer is set to the maximum.

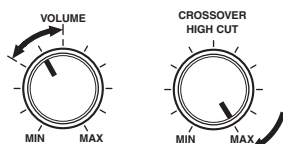

Controls of a subwoofer (example)

2 Connect the supplied optimizer microphone to the OPTIMIZER MIC jack on the front panel.

“SETUP•••••AUTO” appears on the front panel display.

3 Place the optimizer microphone at your normal listening position on a flat level surface with the omni-directional microphone heading upward.

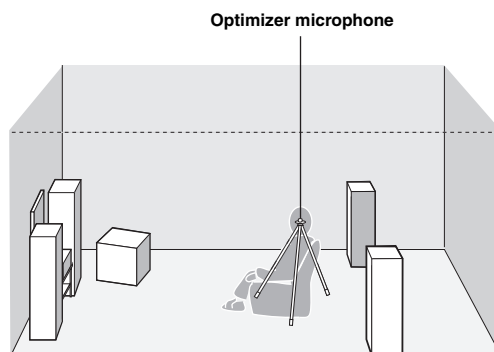

- We recommend that you use a tripod (etc.) to affix the optimizer microphone at the same height as your ears would be when you are seated in your listening position. You can use the attached screw of a tripod (etc.) to fix the optimizer microphone to the tripod (etc.).

4 Press **[F5]** < / > to select “AUTO.”

Choice	Function
AUTO*	Automatically runs the entire “AUTO SETUP” procedure.
RELOAD	Reloads the last “AUTO SETUP” settings and overrides the previous settings.
UNDO	Undoes the last “AUTO SETUP” settings and restores the previous settings.
DEFAULT	Resets the “AUTO SETUP” parameters to the initial factory settings.

Note

- “RELOAD” or “UNDO” is available only when you have previously run “AUTO SETUP” and confirmed the results.

5 Press **[F5]** ENTER to start the setup procedure.

This unit starts the automatic setup procedure. Loud test tones are output from each speaker during the audio setup procedure. After all settings (“INITIALIZING,” “WIRING/LEVEL,” “DISTANCE,” “SIZE”) are sequentially completed, “FINISH” appears on the front panel display.



- To cancel the automatic setup, press **[F5]** Δ.

Notes

- During the automatic setup procedure, do not perform any operation on this unit.
- We recommend that you get out of the room while this unit is in the auto setup procedure. It takes approximately 3 minutes for this unit to complete the auto setup procedure.

6 When all measurements are completed successfully, “FINISH” appears on the front panel display.

The result of the automatic setup for each speaker appears in order on the front panel display.

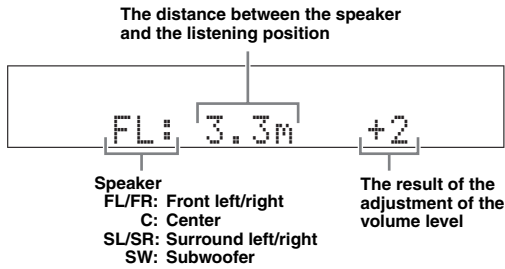

- To display the result of the automatic setup again, press **[12]▲ / ▽** repeatedly.

Notes

- If you select “RELOAD” in step 4, no test tones are output.
- If an error occurs during the “AUTO:CHECK” procedure, the setup procedure is canceled and an error screen appears. For details, see “If an error screen appears” on page 17.
- When this unit detects potential problems during the “AUTO SETUP” procedure, “WARNING” and the warning messages appear after this unit displays the result of the automatic setup. For details, refer to the “AUTO SETUP” section in “Troubleshooting” on page 41.
- The distance measurement result may be longer than the actual distance depending on the characteristics of your subwoofer.

7 Press **[15]◀ / ▶ to select “SET” or “CANCEL.”**

Choice	Function
SET*	Confirms the “AUTO SETUP” results.
CANCEL	Cancels the “AUTO SETUP” results.

8 Press **[15]ENTER to confirm your selection.** “AUTO SETUP” appears on the front panel display.

9 Press **[11]MENU to exit from “SET MENU.”**

10 Disconnect the optimizer microphone from this unit.

The optimizer microphone is sensitive to heat. Keep it away from direct sunlight and do not place it on top of this unit.



- If you change speakers, speaker positions, or the layout of your listening environment, run “AUTO SETUP” again to recalibrate your system.
- When you want to check the result of the automatic setup in detail or manually adjust the parameters, use “MANUAL SETUP” (see page 32).

■ If an error screen appears

If this unit detects the potential problems, an error message appears on the front panel display during the automatic setup.

For details about each error message, see the “AUTO SETUP” section in “Troubleshooting” on page 41.

After a few seconds later, the following choices appear. Press **[15]◀ / ▶** to select “RETRY” or “EXIT” and then press **[15]ENTER**.

Choice	Function
RETRY*	Starts the “AUTO SETUP” again.
EXIT	Exits from the “AUTO SETUP” procedure.

■ If “WARNING” appears

When this unit detects potential problems during the automatic setup procedure, “WARNING” appears on the front panel display after result of each speaker. Check the warning messages to correct your speaker settings.

Note

- Warnings differ from errors in that warnings do not cancel the automatic setup procedure.

Press **[15]▽ to display the detailed information about the warning.**

The detailed information about the warning is displayed and the indicators of inapplicable speakers blink on the front panel display.

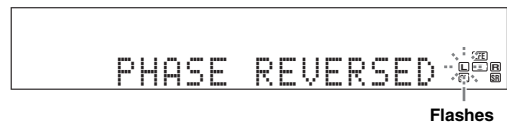

Flashes



- For details about each warning message, see the “AUTO SETUP” section in “Troubleshooting” on page 41.

BASIC OPERATION

Playback

Caution

Extreme caution should be exercised when you play back CDs encoded in DTS. If you play back a CD encoded in DTS on a DTS-incompatible CD player, you will only hear some unwanted noise that may damage your speakers. Check whether your CD player supports CDs encoded in DTS. Also, check the sound output level of your CD player before you play back a CD encoded in DTS.

Basic procedure

- 1 Turn on external components (TV, DVD player, etc.) connected to this unit.
- 2 Press **Ⓢ** **SPEAKERS** repeatedly to select the front speakers you want to use.
The respective speaker indicators lights up on the front panel display.
- 3 Press **Ⓜ** **INPUT** **</>** repeatedly (or press one of the input selector buttons (**5**)) to select the desired input source.
The name of the currently selected input source appears on the front panel display for a few seconds.

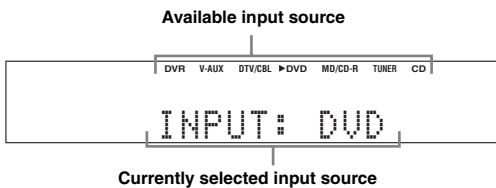

- 4 Start playback on the selected component or select a broadcast station.

Notes

- Refer to the operating instructions for the source component.
- See page 27 for details about FM or AM tuning instructions.



- To adjust the level of each speaker, see page 20.

- 5 Rotate **Ⓜ** **VOLUME** (or press **7** **VOLUME +/-**) to adjust the volume to the desired output level.

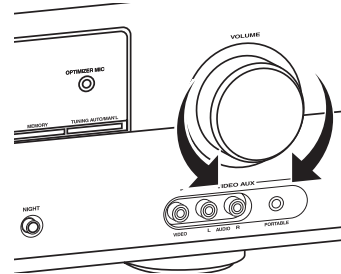

- See page 20 to adjust the level of each speaker.
- This does not affect the AUDIO OUT (REC) level.
- You can set the initial volume level and maximum volume level (see page 34).

- 6 Press **Ⓜ** **PROGRAM** **</>** (or press **21** **PROG** **</>**) repeatedly to select the desired sound field program.

The name of the selected sound field program appears on the front panel display.

See page 22 for details about sound field programs.

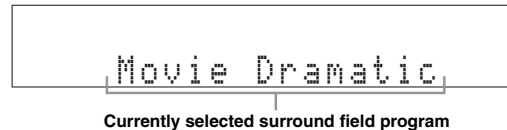

Notes

- Choose a sound field program based on your listening preference, not merely on the name of the program.
- When you select an input source, this unit automatically selects the last sound field program used with the corresponding input source.
- Sound field programs cannot be selected when the component connected to the MULTI CH INPUT jacks is selected as the input source (see page 19).
- When PCM signals with a sampling frequency higher than 48 kHz are input, this unit is automatically set to the "STRAIGHT" mode (see page 26).
- To display information about the currently selected input source on the front panel display, see page 21 for details.

Guide to contents

When you want...	See page
Adjust the tonal quality of the front speakers	20
Edit parameters of sound field programs	26
Enjoy the sources which have wide dynamic range at night	20
Use headphones	20
Select a decoder to play back sources with	26
Set this unit to the standby mode automatically	21

Additional operations

Using input setting features

Use the following features to select input jack or input source.

■ Selecting the front speaker set

Press **Ⓢ****SPEAKERS** repeatedly change the active front speaker set that is connected to the **FRONT A** or **FRONT B** speaker terminals or turn off the front speakers.

The active front speaker set changes as follows:

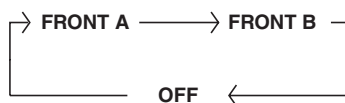

Note

- Turn off the volume level of this unit before you switch the front speaker setting.

■ Using the Zone B feature

When you set “FRONT B” to “ZONE B” (see page 32), you can use the speakers connected to FRONT B speaker terminals in another room (Zone B).

Press **Ⓢ****SPEAKERS** on the front panel repeatedly to turn on or off the Zone B speakers.

When you activate the Zone B speakers, all the speakers in the main room are muted.

Notes

- You cannot activate both the main room and Zone B speakers simultaneously.
- If you select CINEMA DSP sound field program and activate the Zone B speakers, Virtual CINEMA DSP is activated automatically (see page 26).

■ Selecting the component connected to the MULTI CH INPUT jacks as the input source

Use this feature to select the component connected to the MULTI CH INPUT jacks (see page 14) as the input source.

Press **Ⓢ****INPUT** **◀/▶** repeatedly (or press **Ⓢ****MULTI CH IN**) to select “MULTI CH.”

“MULTI CH” appears on the front panel display.



- You can configure the multi channel input settings in “MULTI CH” (see page 35).

Notes

- Sound field programs, or the night listening mode, etc. cannot be selected when “MULTI CH” is selected as the input source.
- When headphones are used, signals are output only from the front left and right channels.

■ Selecting audio input jacks (AUDIO SELECT)

Use this feature (audio input jack select) to switch the input jack assigned to an input source when two or more jacks are assigned to an input source.



- We recommend that you set the audio input jack select to “AUTO” in most cases.
- You can adjust the default audio input jack select of this unit by using “AUDIO SELECT” in “OPTION MENU” (see page 36).

1 Press **Ⓢ****INPUT** **◀/▶** repeatedly (or press one of the input selector buttons (**Ⓢ**)) to select the desired input source.

2 Press **Ⓢ****AUDIO SEL** repeatedly to select the desired Audio input jack select setting.



Audio input jack select setting

Choice	Function
AUTO	Automatically selects input signals in the following order: (1) Digital signals (2) Analog signals
ANALOG	Selects only analog signals. If no analog signals are input, no sound is output.



- You can configure the audio input jack select setting in “AUDIO SELECT.”

Note

- This feature is not available if no digital input jack is assigned to the selected input source in “INPUT ASSIGN” (see page 34).

Using audio features

Use the following features to adjust the audio output or speaker level.

■ Muting the audio output

Press **[8] MUTE** on the remote control to mute the audio output. Press **[8] MUTE** again to resume the audio output.



- You can also rotate **[P] VOLUME** (or press **[7] VOLUME +/-**) to resume the audio output.
- You can configure the muting level by using “MUTE TYP.” in “SOUND MENU” (see page 34).
- The MUTE indicator flashes on the front panel display when the audio output is muted and disappears from the front panel display when the audio output is resumed.

■ Adjusting the tonal quality

Use this feature to adjust the balance of bass and treble for the front left and right speaker channels.

Press **[K] TONE CONTROL** repeatedly to select “BASS” or “TREBLE” and then press **[L] PROGRAM </>** to adjust the corresponding frequency response level.

Control range: -10 dB to +10 dB

Each choice is defined as follows.

Choice	Function
BASS	Adjusts the low-frequency response.
TREBLE	Adjusts the high-frequency response.

Notes

- Speaker and headphone adjustments are stored independently.
- If you increase or decrease the high-frequency or low-frequency sound to an extreme level, the tonal quality of the surround speakers may not match that of the front left and right speakers.
- This does not affect recorded material.

■ Adjusting the speaker level

You can adjust the output level of each speaker while listening to a music source. This is also possible when playing sources input at the MULTI CH INPUT jacks.

Note

- This operation will override the level adjustment made in “SP LEVEL” (see page 33).

1 Press [13] LEVEL repeatedly to select the speaker you want to adjust.

Choice	Description
FRONT L	Front left speaker
FRONT R	Front right speaker
CENTER	Center speaker
SWFR	Subwoofer
SUR. L	Surround left speaker
SUR. R	Surround right speaker



- Once you press **[13] LEVEL** on the remote control, you can also select the speaker by pressing **[15] Δ / ▽**.
- The available speaker channels differ depending on the speaker settings.

2 Press [15] </> on the remote control (or press [F] PRESET/TUNING </>) to adjust the speaker output level.

Control range: -10.0 dB to +10.0 dB

Using optional features

Use the following features to utilize various useful functions equipped on this unit.



- Initial settings are indicated by (*) in this following each parameter.

■ Using your headphones

Connect a pair of headphones with a stereo analog audio cable plug to the PHONES jack on the front panel.



- When you select a sound field program, SILENT CINEMA mode is automatically activated (see page 26).

Notes

- When you connect headphones, no signals are output at the speaker terminals.
- All Dolby Digital and DTS audio signals are mixed down to the left and right headphone channels.

■ Selecting the night listening mode

The night listening modes are designed to improve listenability at lower volumes or at night.

1 Press [O] NIGHT (or press [16] NIGHT) repeatedly to select “NIGHT:CINEMA” or “NIGHT:MUSIC.”

Each choice is defined as follows.

Choice	Function
NIGHT:CINEMA	Narrows the dynamic range of film soundtracks and makes dialog easier to hear at lower volumes.
NIGHT:MUSIC	Preserves ease-of-listening for all sounds.
NIGHT OFF	Disables this feature.



- When a night listening mode is selected, the NIGHT indicator lights up on the front panel display.

2 Press **[15]** </> to adjust the effect level while “NIGHT:CINEMA” or “NIGHT:MUSIC” is displayed on the front panel display.

Each choice is defined as follows.

Choice	Function
MIN	Slightly lowers the effect level.
MID*	Moderately lowers the effect level.
MAX	Considerably lowers the effect level.



- “NIGHT:CINEMA” and “NIGHT:MUSIC” adjustments are stored independently.

Notes

- You cannot use the night listening modes in the following cases:
 - when the component connected to the MULTI CH INPUT jacks is selected as the input source.
 - when headphones are connected to the PHONES jack.
 - when the sampling frequency of the input sources are higher than 48 kHz.
- The effect of night listening modes may vary depending on the input source and surround sound settings you use.

■ Displaying the input source information (SIGNAL INFO)

You can display the format, sampling frequency, channel, bit rate and flag data of the current input signal.

1 Press **[11]** MENU on the remote control.

“AUTO SETUP” appears on the front panel display.

• AUTO SETUP

2 Press **[15]** Δ / ∇ repeatedly to select “SIGNAL INFO” and then press **[15]** ENTER.

3 Press **[15]** Δ / ∇ to switch the displayed information.

The following information about the input source appears on the front panel display.

Choice	Description
FORMAT	Signal format.
SAMPLING	The number of samples per second taken from a continuous signal to make discrete signals.
CHANNEL	The number of source channels in the input signal (front/surround/LFE).
BITRATE	The number of bits passing a given point per second.
FLAG	Flag data encoded in DTS, Dolby Digital, or PCM signals that cue this unit to automatically switch decoders.

4 Press **[11]** MENU on the remote control again to exit from “SET MENU.”

■ Using the sleep timer

Use this feature to automatically set this unit to the standby mode after a certain amount of time. The sleep timer is useful when you are going to sleep while this unit is playing or recording from a source.

Press **[12]** SLEEP repeatedly to set the amount of time.

The sleep timer setting changes as follows.

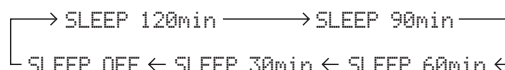

Once the sleep timer is set, the SLEEP indicator lights up on the front panel display, and the display returns to the selected sound field program.

To cancel the sleep timer

Press **[12]** SLEEP on the remote control repeatedly to select “SLEEP OFF.”



- If you set the main zone to the standby mode, the sleep timer is automatically canceled.

■ Playing video sources in the background

You can combine a video image from a video source with sound from an audio source. For example, you can enjoy listening to classical music while viewing beautiful scenery from the video source on the video monitor.

Press the input selector buttons (**[5]**) on the remote control to select a video source and then an audio source.

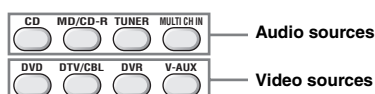

Selecting the SCENE templates

Just by pressing one SCENE button, you can recall your favorite input source and sound field program according to the SCENE template that has been assigned to the SCENE button. The SCENE templates are built combinations of input sources and sound field programs.

This unit is equipped with 12 preset SCENE templates for various situations. The following SCENE templates are assigned to respective SCENE buttons in the default settings.

Default SCENE button	The name of the SCENE template and its description
SCENE 1	DVD Movie Viewing – input source: DVD – sound field program: STRAIGHT For when you want to enjoy a DVD playback.
SCENE 2	Music Disc Listening – input source: DVD – sound field program: 2ch Stereo For when you want to listen to a music disc from the connected DVD player.
SCENE 3	TV Viewing *1 – input source: DTV/CBL – sound field program: STRAIGHT For when you want to watch a TV program.
SCENE 4	Radio Listening *2, *3, *4 – input source: TUNER – sound field program: Music Enh. 5ch For when you want to listen to a music program from the FM radio station.

Notes

- *1 You must connect a cable TV or a satellite tuner to this unit in advance. See page 13 for details.
- *2 You need to connect the supplied FM and AM antennas to this unit in advance. See page 15 for details.
- *3 You have to tune into the desired radio station. See pages 27 to 28 for the tuning information.
- *4 To achieve the best possible reception, orient the connected AM loop antenna, or adjust the position of the end of the indoor FM antenna.

Selecting the desired SCENE template

If you want to use other SCENE templates, you can select the desired SCENE templates from the SCENE template library and assign the templates to the selected SCENE buttons on the front panel and the remote control.

Select the desired SCENE template

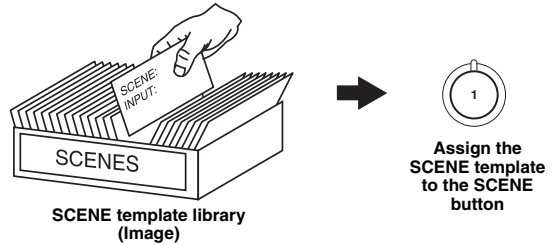

- 1 Press and hold the desired \downarrow SCENE (or $\boxed{4}$ SCENE) button for 3 seconds.**

The MEMORY indicator on the front panel starts to flash, and the name of currently assigned SCENE template appears on the front panel display.

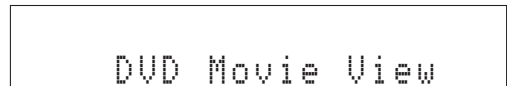

- 2 Press N INPUT $\triangleleft/\triangleright$ (or press $\boxed{15}$ $\triangleleft/\triangleright$) to select the desired template.**



- 3 Press the \downarrow SCENE (or $\boxed{4}$ SCENE) button again to confirm the selection.**

The MEMORY indicator stops flashing and the select SCENE template is assigned to the button.



- To cancel the procedure, press $\boxed{17}$ RETURN.

Which SCENE template would you like to select?

The following tables indicate preset SCENE template descriptions. Select the corresponding SCENE templates for the desired source. The illustrations of the SCENE button in the following table indicate that the SCENE templates in those cells are assigned to the SCENE buttons, respectively.

You can also create your original SCENE templates by editing the preset SCENE templates. See page 24 for details.

■ Video sources (DVD video, Recorded video)

SCENE template	Input source	Playback mode	Features
DVD Viewing	DVD	STRAIGHT	Select this SCENE template when you play back general contents on your DVD player.
 DVD Movie Viewing	DVD	Movie Dramatic	Select this SCENE template when you play back movies on your DVD player.
DVD Live Viewing	DVD	Pop/Rock	Select this SCENE template when you enjoy music live video on your DVD player.
DVR Viewing	DVR	Movie Dramatic	Select this SCENE template when you play back movies on your digital video recorder.

■ Music discs (CD, SA-CD or DVD-Audio)

SCENE template	Input source	Playback mode	Features
 Music Disc Listening	DVD	2ch Stereo	Select this SCENE template when you play back music discs on your DVD player.
Disc Listening	DVD	5ch Stereo	Select this SCENE template when you play back music sources as the back ground music on your DVD player.
CD Listening	CD	5ch Stereo	Select this SCENE template when you play back music source as the back ground music on your CD player.
CD Music Listening	CD	2ch Stereo	Select this SCENE template when you play back music discs on your CD player.

■ Radio programs

SCENE template	Input source	Playback mode	Features
 Radio Listening	TUNER	Music Enh. 5ch	Select this SCENE template when you enjoy FM or AM radio programs.

■ TV programs

SCENE template	Input source	Playback mode	Features
 TV Viewing	DTV/CBL	STRAIGHT	Select this SCENE template when you enjoy TV programs.
TV Sports Viewing	DTV/CBL	TV Sports	Select this SCENE template when you enjoy sports programs on TV.

■ Video games

SCENE template	Input source	Playback mode	Features
Game Playing	V-AUX	Game	Select this SCENE template when you play video games.

Creating your original SCENE templates

You can create your original SCENE templates for each SCENE button. Refer to the preset 12 SCENE templates to create the original SCENE templates.

Customizing the preset SCENE templates

Use this feature to customize the preset SCENE templates.

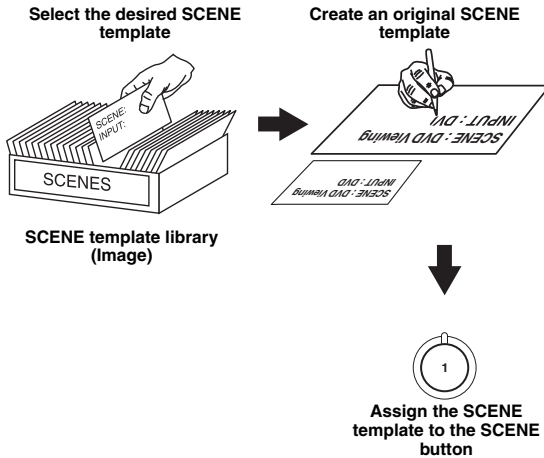

1 Press and hold the desired **[4]SCENE** button for 3 seconds.

The MEMORY indicator on the front panel starts to flash.



Note

- When the SCENE template you want to customize is not assigned to any of the **[4]SCENE** button, press **[15]</>** repeatedly to recall the desired SCENE template (see page 22).

2 Press **[15]▲ / ▼** to select the desired parameter of the SCENE template and then **[15]</>** to select the desired value of the selected parameter.

You can adjust the following parameters for a SCENE template:

- The input source component
- The active sound field programs or STRAIGHT mode
- The night listening mode setting (see page 20)
 - SYSTEM: Keeps the current night listening mode.
 - CINEMA: Sets the night listening mode to the CINEMA mode.
 - MUSIC: Sets the night listening mode to the MUSIC mode.

3 Press the **[9]SCENE** button again to confirm the edit.



- An asterisk mark (*) appears by the name of the original SCENE template.
- To cancel the procedure, press **[17]RETURN**.

Notes

- You can create a customized SCENE template for each **[4]SCENE** button, and if you create another customized SCENE template, this unit overwrites the old customized SCENE template with the new one.
- The customized SCENE template is only available for the assigned **[4]SCENE** button.

Sound field programs

This unit is equipped with a variety of precise digital decoders that allow you to enjoy multi-channel playback from almost any stereo or multi-channel sound source. This unit is also equipped with a Yamaha digital sound field processing (DSP) chip containing several sound field programs which you can use to enhance your playback experience.

Selecting sound field programs

Press **PROGRAM** \triangleleft / \triangleright (or press **PROG** \triangleleft / \triangleright repeatedly).

The name of the selected sound field program appears on the front panel display and on the OSD.

Sound field program descriptions



- Select a sound field program based on your listening preference, not merely on the name of the program, etc.
- The available sound field parameters differ depending on the settings of the speakers.

Notes

- When you select an input source, this unit automatically selects the last sound field program used with corresponding input source.
- Sound field programs cannot be selected when the component connected to the MULTI CH INPUT jacks is selected as the input source (see page 19).
- When PCM signals with a sampling frequency higher than 48 kHz are input, this unit is automatically set to the “STRAIGHT” mode (see page 26).



- Choose a sound field program based on your listening preference, not merely on the name of the program itself.
- You can select “Music Enh. 2ch” and “Music Enh. 5ch” by pressing **ENHANCER** repeatedly.

Category	Program	Features
MUSIC	Pop/Rock	CINEMA DSP processing. This program presents an image of pop, rock, or jazz live concert. The sound field reproduces the spaciousness of a massive pavilion with an emphasis on the vividness of vocals on the stage and solo instruments and the beats of rhythm instruments.
	Hall	CINEMA DSP processing. This sound field is suitable for classic and orchestral music. The program uses data collected in a large concert hall in Munich. You can enjoy delicate and beautiful reverberation and a majestic atmosphere.
	Jazz	CINEMA DSP processing. The sound field is suitable for jazz and fusion music. It uses data collected in a famous jazz club in New York. You can enjoy clear reverberation.
ENTERTAIN	Game	CINEMA DSP processing. You can enjoy dynamic and thrilling sound effects as you play games. The program lets you feel the depth and three-dimensional surrounding sounds of the field where you are playing, and offers cinema-like surrounding sound effects for the scenes of movies.
	TV Sports	CINEMA DSP processing. You can enjoy sports relays broadcast in stereo and variety shows with a live sound environment. For sports relays, the voices of commentators and announcers come clearly from the center; the cheers and atmosphere in the stadium spread around within a comfortable range, and you can feel like as if you are in the stadium.
MOVIE	Movie Spacious	CINEMA DSP processing. The sound field is suitable for movies with an emphasis on spectacular sound effects, and is a perfect fit with a wide screen. The program reproduces a wide dynamic range from minimum sound effects to powerful sounds.
	Movie Dramatic	CINEMA DSP processing. This sound field is also suitable for movies with an emphasis on three-dimensional sound effects. It restrains reverberation to an moderate extent, but reproduces sound effects and background music in a soft, three-dimensional manner with clarity and center orientation of voices as pivots.
STEREO	2ch Stereo	Downmixes multi-channel sources to 2 channel or plays back 2-channel sources as they are.
	5ch Stereo	CINEMA DSP processing. Using this program increases the listening position range. This is a sound field suitable for background music at parties.
ENHANCER	Music Enh. 2ch Music Enh. 5ch	Select these programs to play back compression artifacts (such as the MP3 format) in 2-channel or 5-channel stereo. This program enhances your listening experience by regenerating the missing harmonics in a compression artifact.

■ **Selecting decoders for 2-channel sources (surround decode mode)**

Signals input from 2-channel sources can also be played back on multi-channels.

Press **[18] SUR. DECODE** repeatedly to select a decoder.

You can select from the following decoders depending on the type of source you are playing and your personal preference.

STANDARD	Function
PRO LOGIC	Dolby Pro Logic processing for any sources
PLII Movie	Dolby Pro Logic II processing for movie sources
PLII Music	Dolby Pro Logic II processing for music sources
PLII Game	Dolby Pro Logic II processing for game sources

■ **Editing sound field parameters**

Although you can enjoy good quality sound with the factory default parameters, you can change some of the parameters to better suit the input source or your listening room.

1 While listening to a source, press **[15]▲ / ▼** to select desired parameter.

2 Press **[15]◀ / ▶** to change the parameter value.

Note

• You cannot change parameter values when “MEM.GUARD” in “OPTION MENU” is set to “ON” (see page 35).



• Initial settings are indicated by (*) in the following each parameter.

For Pop/Rock, Hall, Jazz, Game, TV Sports, Movie Spacious and Movie Dramatic:

DSP level DSP LEVEL

Function:	Adjusts the effect level.
Choices:	MIN, MID*, MAX

For PRO LOGIC II Music:

Panorama PANORAMA

Function:	Sends stereo signals to the surround speakers as well as the front speakers for a wraparound effect.
Choices:	OFF*, ON

Dimension DIMENSION

Function:	Gradually adjusts the sound field either towards the front or towards the rear.
Control range:	-3 (towards the rear) to +3 (towards the front), initial setting is STD (standard).

Center width CT WIDTH

Function:	Adjusts the center image from all three front speakers to varying degrees. A larger value adjusts the center image towards the front left and right speakers.
Control range:	0 (center channel sound is output only from center speaker) to 7 (center channel sound is output only from front left and right speakers), initial setting is 3.

For Music Enh. 2ch and Music Enh. 5ch

Effect level

Function:	Adjusts the effect level.
Choices:	LOW, HIGH*

■ **Using sound field programs without surround speakers (Virtual CINEMA DSP)**

Virtual CINEMA DSP allows you to enjoy the CINEMA DSP sound field programs without surround speakers. When you set “SUR. L/R” to “NONE” (see page 33), Virtual CINEMA DSP is activated automatically whenever you select a CINEMA DSP sound field program (see page 25).

■ **Enjoying multi-channel sources and sound field programs with headphones (SILENT CINEMA)**

SILENT CINEMA allows you to enjoy multi-channel music or movie sound through ordinary headphones. SILENT CINEMA is activated automatically whenever you connect headphones to the PHONES jack while listening to CINEMA DSP sound field programs (see page 25).



• When it is activated, the SILENT CINEMA indicator lights up on the front panel display.

■ **Enjoying unprocessed input sources (Straight decoding mode)**

When this unit is in the “STRAIGHT” mode, 2-channel stereo sources are output from only the front left and right speakers. Multi-channel sources are decoded straight into the appropriate channels without any additional effect processing.

Press **[M] STRAIGHT** (or press **[20] STRAIGHT**) to select “STRAIGHT.”

“STRAIGHT” appears on the front panel display.

To deactivate the “STRAIGHT” mode

Press **[M] STRAIGHT** (or **[20] STRAIGHT**) again so that “STRAIGHT” disappears from the front panel display.

FM/AM tuning

Overview

You can use two tuning modes to tune into a desired FM/AM station:

■ Frequency tuning mode

You can search or specify the frequency of the desired FM/AM station automatically or manually (see “FM/AM tuning operations” on this page).

■ Preset tuning mode

You can preset the desired FM/AM station in advance, and then recall the station by specifying the preset group and number (see “Selecting preset stations” on page 28).

Note

- Orient the connected AM loop antenna, or adjust the position of the end of the indoor FM antenna for the best reception.

FM/AM tuning operations

- 1 Press **ⓂINPUT** $\triangleleft/\triangleright$ repeatedly so that “TUNER” is displayed on the front panel display.
- 2 Press **ⓄBAND** to select the reception band (FM or AM).
- 3 To search the station automatically, press **ⓂTUNING AUTO/MAN'L** so that the AUTO indicator lights up on the front panel display. To search the station manually, press **ⓂTUNING AUTO/MAN'L** again so that the AUTO indicator disappears from the front panel display.

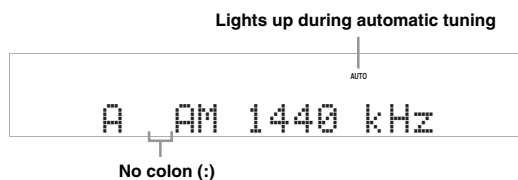

If a colon (:) appears on the front panel display, automatic/manual tuning is not possible. Press **ⓄEDIT PRESET/TUNING** to turn the colon (:) off.

- 4 To begin automatic tuning, press **ⓄPRESET/TUNING** $\triangleleft/\triangleright$ once. To tune into the desired station manually, press **ⓄPRESET/TUNING** $\triangleleft/\triangleright$ repeatedly. When this unit is tuned into a station, the TUNED indicator lights up and the frequency of the received station is shown on the front panel display.
 - To tune into a higher frequency, press **ⓄPRESET/TUNING** \triangleright .

- To tune into a lower frequency, press **ⓄPRESET/TUNING** \triangleleft .

Note

- If the signal from the station you want to select is weak, tune into it manually.

Preset FM/AM stations

Use this feature to store up to 40 stations (A1 to E8: 8 preset station numbers in each of 5 preset station groups). Preset the desired stations to this unit by using the automatic or manual station preset.

Automatic station preset

You can use the automatic preset tuning feature to store up to 40 FM stations with strong signals in order.

- 1 Press **ⓂINPUT** $\triangleleft/\triangleright$ repeatedly so that “TUNER” is displayed on the front panel display.
- 2 Press **ⓄBAND** to select “FM” as the reception band.
- 3 Press and hold **ⓄMEMORY** for more than 3 seconds. The preset station number as well as the MEMORY and AUTO indicators flashes. After approximately 5 seconds, automatic presetting status from the current frequency and proceeds toward the higher frequencies.

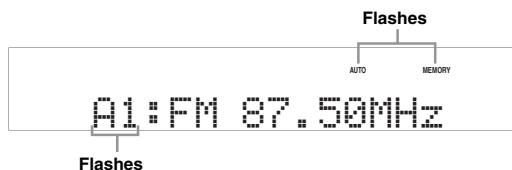

When automatic preset tuning is completed, the front panel display shows the frequency of the last preset station.

- You can select the preset station group and the preset station number where the first received station will be stored by pressing **ⓄA/B/C/D/E** and then **ⓄPRESET/TUNING** $\triangleleft/\triangleright$.

Notes

- Any stored station data existing under a preset station number is cleared when you store a new station under the same preset station number.
- Only FM stations with sufficient signal strength are stored automatically by automatic preset tuning. If the station you want to store is weak in signal strength, tune it manually and store it as described in “Manual station preset” on page 28.
- Only Radio Data System broadcasting station are stored automatically by automatic preset tuning (Europe model only).

Manual station preset

Use this feature to store the FM or AM stations manually.

1 Tune into a station.

See page 27 for using instructions.

2 Press **Ⓜ**MEMORY.

The MEMORY indicator flashes on the front panel display for approximately 30 seconds.

3 Press **Ⓜ**A/B/C/D/E and **Ⓟ**PRESET/TUNING **◀/▶** repeatedly to select a preset station group and number (A1 to E8) while the MEMORY indicator is flashing.

Check that the colon (:) appears on the front panel display.

- To select a higher preset station group and number, press **Ⓟ**PRESET/TUNING **▶**.
- To select a lower preset station group and number, press **Ⓟ**PRESET/TUNING **◀**.

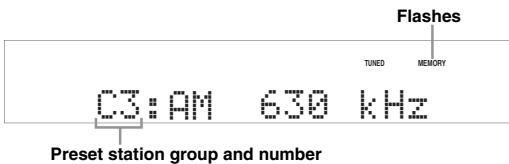

4 Press **Ⓜ**MEMORY while the MEMORY indicator is flashing.

The station band and frequency appear on the front panel display with the preset station group and number you have selected.



Selecting preset stations

You can tune into any desired station simply by selecting the preset station group and number under which it is stored.

When performing this operation with the remote control, press **5**TUNER to select “TUNER” as the input source.

1 Press **Ⓜ**A/B/C/D/E (or **10**A/B/C/D/E) repeatedly to select the desired preset station group (A to E).

The preset station group letter appears on the front panel display and changes each time you press the button.

2 Press **Ⓟ**PRESET/TUNING **◀/▶** (or **9**PRESET **◀/▶**) to select the desired preset station number (1 to 8).

The preset station group and number, along with station band and frequency, appear on the front panel display.

Exchanging preset stations

You can exchange the assignments of two preset stations between the two. The example below describes the procedure to exchange preset station “E1” and “A5.”

1 Select preset station “E1” using **Ⓜ**A/B/C/D/E and **Ⓟ**PRESET/TUNING **◀/▶**.

See “Selecting preset stations” on this page.

2 Press and hold **Ⓝ**EDIT PRESET/TUNING for more than 3 seconds.

“E1” and the MEMORY indicator flash on the front panel display.

3 Select preset station “A5” using **Ⓜ**A/B/C/D/E and **Ⓟ**PRESET/TUNING **◀/▶**.

“A5” and the MEMORY indicator flash on the front panel display.

See “Selecting preset stations” on this page.

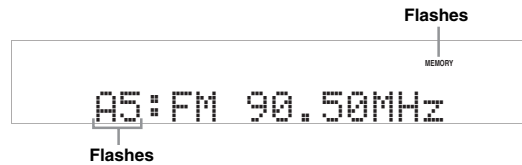

4 Press **Ⓝ**EDIT PRESET/TUNING again.

“EXCHANGE E1-A5” appears on the front panel display and the assignments of the two preset stations are exchanged.

Radio Data System tuning (Europe and Russia models only)

Radio Data System is a data transmission system used by FM stations in many countries. This unit can receive various Radio Data System data such as PS (program service), PTY (program type), RT (radio text), CT (clock time), and EON (enhanced other networks) when receiving Radio Data System broadcasting stations.

Displaying the Radio Data System information

Use this feature to display the 4 types of the Radio Data System information: PS (program service), PTY (program type), RT (radio text) and CT (clock time). The corresponding indicators light up on the front panel display (see page 4).

Notes

- Radio Data System display mode varies depending on the current broadcasting station.
- It may take a while for this unit to receive all of the Radio Data System data from the station.
- If the signals being received are not strong enough, this unit may not be able to utilize the Radio Data System data.
- In case of poor reception conditions, press **TUNING AUTO/MAN'L** on the front panel so that the AUTO indicator disappears from the front panel display.

1 Tune into the desired Radio Data System broadcasting station.



- We recommend that you use the automatic preset tuning to tune into the Radio Data System broadcasting stations (see page 27).
- You can also use PTY SEEK mode to tune into the desired Radio Data System broadcasting station from the preset ones.

2 Press **INFO** on the remote control repeatedly to select the desired Radio Data System display mode.

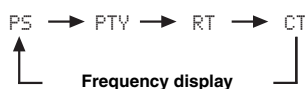

Choice	Function
PS	Displays the name of the Radio Data System program currently being received.
PTY	Displays the type of the Radio Data System program currently being received.
RT	Displays the information on the Radio Data System program currently being received.
CT	Displays the current time.

Selecting the Radio Data System program type (PTY SEEK mode)

Use this feature to select the desired radio program by program type from the all preset Radio Data System broadcasting stations.



- Use the automatic preset tuning feature to preset Radio Data System broadcasting stations (see page 27).

1 Press **TUNER** on the remote control to select “TUNER” as the input source.

2 Press **PTY SEEK MODE** on the remote control to set this unit to the PTY SEEK mode.

The name of the program type or “NEWS” flashes on the front panel display.



- To cancel the PTY SEEK mode, press **PTY SEEK MODE** on the remote control again.

3 Press **PRESET** on the remote control to select the desired program type.

The remote of the selected program type appears on the front panel display.

Program type	Description
NEWS	News
AFFAIRS	Current affairs
INFO	General information
SPORT	Sports
EDUCATE	Education
DRAMA	Drama
CULTURE	Culture
SCIENCE	Science
VARIED	Light entertainment
POP M	Popular music
ROCK M	Rock music
M.O.R. M	Middle-of-the-road music (easy-listening)
LIGHT M	Light classics
CLASSICS	Serious classics
OTHER M	Other music

4 Press  PTY SEEK START on the remote control to start searching for all the available Radio Data System preset stations.

The name of the selected program type flashes and the PTY HOLD indicator lights up on the front panel display.



- To stop searching for stations, press  PTY SEEK START on the remote control again.

Note

- Press  PTY SEEK START again to resume searching for another station broadcasting the same program type.

Using the enhanced other networks (EON) data service

Use this feature to receive the EON (enhanced other networks) data service of the Radio Data System station network. Once you select one of the 4 Radio Data System program types (NEWS, AFFAIRS, INFO or SPORT), this unit automatically searches for all the available preset stations that are scheduled to broadcast the EON data service of the selected program type for a certain duration of time. When the scheduled EON data service starts, this unit automatically switches to the local station broadcasting the EON data service and then switches back to the national station once the EON data service ends.

Notes

- You can use this feature only when the EON data service is available.
- The EON indicator lights up on the front panel display only when the EON data service is being received from a Radio Data System station.

1 Tune into the desired Radio Data System broadcasting station.

2 Make sure the EON indicator is lit on the front panel display.

If the EON indicator is not lit on the front panel display, select another Radio Data System program so that the EON indicator lights up.

3 Press  EON on the remote control repeatedly to select one of the 4 Radio Data System program types (NEWS, AFFAIRS, INFO or SPORT).

The name of the selected program type appears on the front panel display.



- To cancel the EON feature, press  EON on the remote control repeatedly until the name of the program type disappears and "EON OFF" appears on the front panel display.

ADVANCED OPERATION

Set menu

You can use the following parameters in the set menu to adjust a variety of system settings and customize the way this unit operates. Change the initial settings to reflect the needs of your listening environment.

Auto setup AUTO SETUP

Use this feature to automatically adjust speaker and system parameters (see page 16).

Manual setup MANUAL SETUP

Use this feature to manually adjust speaker and system parameters.

■ Sound menu 1 SOUND MENU

Use this menu to manually adjust any speaker settings, alter the quality and tone of the sound output by the system or compensate for video signal processing delays when using LCD monitors or projectors.

Parameter	Features	Page
A)SPEAKER SET	Selects the size of each speaker, the speakers for low-frequency signal output, the crossover frequency, and the location of the front speakers connected to the FRONT B terminals.	32
B)SP LEVEL	Adjusts the output level of each speaker.	33
C)SP DISTANCE	Adjusts the distance of each speaker.	33
D)CENTER GEQ	Adjusts the tonal quality of the center speaker.	33
E)LFE LEVEL	Adjusts the output level of the LFE channel for Dolby Digital or DTS signals.	34
F)D. RANGE	Adjusts the dynamic range of Dolby Digital or DTS signals.	34
G)AUDIO SET	Adjusts the muting level, audio delay settings, maximum volume level and initial volume level.	34

■ Input menu 2 INPUT MENU

Use this menu to manually reassign the input jacks, select the input mode or rename the input source.

Parameter	Features	Page
A)INPUT ASSIGN	Assigns the input jacks on this unit according to the component to be used.	34
B)INPUT RENAME	Changes the name of the input source.	35
C)VOLUME TRIM	Adjusts the output volume of each jack.	35
D)DECODER MODE	Selects the decoder mode for the sources connected to the DIGITAL INPUT jacks on the rear panel of this unit.	35
E)MULTI CH SET	Select the video source played in the background of the sources input from the MULTI CH INPUT jacks.	35

■ Option menu 3 OPTION MENU

Use this menu to manually adjust the optional system parameters.

Parameter	Features	Page
A)DISPLAY SET	Adjusts the brightness of the front panel display.	35
B)MEMORY GUARD	Locks sound field program parameters and other set menu settings.	35
C)AUDIO SELECT	Designates the default audio input jack select setting mode for the input sources connected to the DIGITAL INPUT jacks when you turn on the power of this unit.	36
D)PARAM. INI	Sets all the parameters of the sound field programs to the initial factory settings.	36

Signal information SIGNAL INFO

Use this feature to check audio signal information (see page 21).

Using set menu

Use the remote control to access and adjust each parameter.



- You can change the set menu parameters while this unit is reproducing sound.

1 Press [11] MENU on the remote control.
“AUTO SETUP” appears on the front panel display.

2 Press [15] Δ / ▽ to select “MANUAL SETUP.”

• MANUAL SETUP

3 Press [15] ENTER to enter “MANUAL SETUP.”
“1 SOUND MENU” appears on the front panel display.

1 SOUND MENU

4 Press [15] Δ / ▽ repeatedly and then press [15] ENTER to select and enter the desired menu.

The following menus appear on the front panel display as you press [15] Δ / ▽ repeatedly.

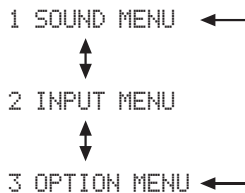

5 Press [15] Δ / ▽ repeatedly and then press [15] ENTER to select and enter the desired submenu.

- Repeat this step to navigate to and enter the items you want to adjust.
- To return to the previous menu level, press [17] RETURN.

6 Press [15] Δ / ▽ to select the desired parameter and then [15] < / > to change the parameter value.

- Press [15] > to increase the value.
- Press [15] < to decrease the value.

7 Press [11] MENU to exit from set menu.

1 SOUND MENU

Use this menu to manually adjust any speaker settings or compensate for video signal processing delays when using LCD monitors or projectors.



- Initial settings are indicated by (*) in this following each parameter.

Speaker settings A) SPEAKER SET

Use this feature to manually adjust any speaker settings.

■ FRONT B speaker setting FRONT B

Use this feature to select the location of the front speakers connected to the FRONT B terminals.

Choice	Condition
FRONT*	When FRONT B speakers are set in the main zone.
ZONE B	When FRONT B speakers are set in another zone. This setting mutes all the speakers in the main room when FRONT B is selected by ©SPEAKERS.

Notes

- If you connect headphones to the PHONES jack on this unit, the sound is output from both headphones and the FRONT B terminals while “FRONT B” is set to “ZONE B.”
- If a DSP program is selected when “FRONT B” is set to “ZONE B,” this unit automatically enters the Virtual CINEMA DSP mode (see page 26).

■ Front speakers, Center speaker, Surround left/right speakers

FRONT, CENTER, SUR. LR

Select “LARGE (LRG)” or “SMALL (SML)” depending on the size of your each speaker. When Center speaker or Surround speakers is not connected, select “NONE.”

Initial setting:

FRONT: “LARGE”

CENTER: “SML”

SUR. LR: “SML”

Woofers diameter of a speaker is 16 cm (6.5 in) or

larger: LARGE (LRG)

Woofers diameter of a speaker is smaller than 16 cm (6.5 in): SMALL (SML)

Notes

- When “BASS OUT” is set to “FRONT” on this page, you can select only “LARGE” in “FRONT.” If “FRONT” is set to a setting other than “LARGE” in advance, this unit automatically changes the value to “LARGE.”
- When you select “NONE” in “CENTER,” the center channel signals are directed to the front left and right speakers.
- When you select “NONE” in “SUR. LR,” this unit is automatically enters the Virtual CINEMA DSP mode (see page 26).

■ LFE/Bass out BASS OUT

Use this feature to select the speakers that output the LFE (low-frequency effect) and the low-frequency signals.



- If you are not satisfied with the bass sounds from your speakers, you can change these settings according to your preference.

LFE signals output

Choice	Subwoofer	Front speakers	Other speakers
BOTH*	Output	No output	No output
SWFR	Output	No output	No output
FRONT	No output	Output	No output

Low-frequency signals output

Choice	Subwoofer	Front speakers	Other speakers
BOTH*	*1	*2	*3
SWFR	*4	*3	*3
FRONT	No output	*1	*3

Notes

- *1 Outputs the low-frequency signals of the front channels and other speakers to “SML” or “NONE.”
- *2 Always output the low-frequency signals of the front channels.
- *3 Output the low-frequency signals if the sizes of speakers are set to “LARGE” (or “LRG”).
- *4 Output the low-frequency signals of the speakers set to “SML.”

■ Crossover CROSSOVER

Use this feature to select a crossover frequency of all the speakers set to “SML” (or “SMALL”) or to “NONE” in “SPEAKER SET” (see pages 31 and 32).

Choices: 40Hz, 60Hz, 80Hz*, 90Hz, 100Hz, 110Hz, 120Hz, 160Hz, 200Hz

Note

- All frequencies below the selected frequency will be sent to the subwoofer or to the speakers set to “LRG” (or “LARGE”) in “SPEAKER SET” (see pages 31 and 32).

■ Subwoofer phase SWFR PHASE

Use this feature to switch the phase of your subwoofer if bass sounds are lacking or unclear.

Choice	Function
NRM*	Does not reverse the phase of your subwoofer.
REV	Sets the phase of your subwoofer to reverse.

Speaker level B)SP LEVEL

Use this feature to manually adjust the output level of each speaker.

Control range: -10 dB to 0 dB* to +10 dB

Control step: 1 dB

SP LEVEL	Adjusted speaker
FL	Front left speaker
FR	Front right speaker
C	Center speaker
SL	Surround left speaker
SR	Surround right speaker
SWFR	Subwoofer

Notes

- The available speaker channels differ depending on the setting of the speakers.
- This does not affect recorded material.

Speaker distance C)SP DISTANCE

Use this feature to manually adjust the distance of each speaker and the delay applied to the respective channel. All sounds would be adjusted to arrive at the listening position at the same time regardless of distance from each speaker.

■ Unit UNIT

Choice	Condition
meters*	When you adjust speaker distances in meters.
feet	When you adjust speaker distances in feet.

■ Speaker distances

Control range: 0.30 to 24.00 m (1.0 to 80.0 ft)

Control step: 0.10 m (0.5 ft)

Initial setting:

FRONT L/FRONT R/SWFR: 3.00 m (10.0 ft)

CENTER: 2.60 m (8.5 ft)

SUR. L/SUR. R: 2.40 m (8.0 ft)

SP DISTANCE	Adjusted speaker
FRONT L	Front left speaker
FRONT R	Front right speaker
CENTER	Center speaker
SUR. L	Surround left speaker
SUR. R	Surround right speaker
SWFR	Subwoofer

Note

- The available speaker channels differ depending on the setting of the speakers.

Center graphic equalizer D)CENTER GEO

Use this feature to adjust the built-in 5-frequency band (100Hz, 300Hz, 1kHz, 3kHz and 10kHz) graphic equalizer for the center channel so that the tonal quality of the center speaker matches that of the front speakers.

Control range: -6.0 dB to 0 dB* to +6.0 dB

Control step: 0.5 dB



- Press $\boxed{10}$ / $\boxed{\Delta}$ / $\boxed{\nabla}$ to select a frequency band and $\boxed{1}$ / $\boxed{\leftarrow}$ / $\boxed{\rightarrow}$ to adjust the selected frequency band.
- You can make adjustment while listening to the currently source or a test tone.

Following is an example where “100Hz” is selected as the frequency band.



■ Test tone TEST

Use this feature to make adjustments for “CENTER GEQ” while listening to a test tone.

Choice	Function
OFF*	Stops test tones and output the currently.
ON	Outputs test tones from the center and from left speakers.

Low-frequency effect level E\LFE LEVEL

Use this feature to adjust the output level of the LFE (low-frequency effect) channel according to the capacity of your subwoofer or headphones.

Control range: -20 dB to 0 dB*

Control step: 1 dB

■ Speaker LFE SP LFE

Adjusts the speaker LFE level.

■ Headphone LFE HP LFE

Adjusts the headphone LFE level.

Notes

- Depending on the settings of “BASS OUT” (see page 32), some signals may not be output at the SUBWOOFER OUTPUT jack.
- The LFE channel carries low-frequency special effects which are only added to certain scenes.
- This setting is effective when the input signal contains the LFE channel.

Dynamic range F\D.RANGE

Use this feature to select the amount of dynamic range compression to be applied to your speakers or headphones. This setting is effective only when this unit is decoding Dolby Digital and DTS signals.

Choice	Function
MIN	Adjusts the dynamic range to narrow.
STD	Adjusts the dynamic range to medium.
MAX*	Preserves the greatest amount of dynamic range.

■ Speaker dynamic range SP D.R

Adjusts the speaker compression.

■ Headphone dynamic range HP D.R

Adjusts the headphone compression.

Audio settings G\AUDIO SET

Use this feature to adjust the overall audio settings of this unit.

■ Mute type MUTE TYP.

Use this feature to adjust how much the mute function reduces the output volume (see page 20).

Choice	Function
FULL*	Completely mutes all the audio output.
-20dB	Reduces the current volume by 20 dB.

■ Audio delay A.DELAY

Use this feature to delay the sound output and synchronize it with the video image. This may be necessary for certain LCD monitors or projectors.

Control range: 0 ms* to 160 ms

Control step: 1 ms

■ Maximum volume MAX VOL.

Use this feature to set the maximum volume level regardless of the original volume range. This feature is useful to avoid the unexpected loud sound.

Control range: +16 dB*, +10 dB to -30 dB

Control step: 5 dB

Note

- The “MAX VOL.” setting takes priority over the “INI.VOL.” setting. For example, if “INI.VOL.” is set to -20 dB and “MAX VOL.” is set to -30 dB, the volume level is automatically set to -30 dB when you turn on the power of this unit next time.

■ Initial volume INI.VOL.

Use this feature to set the volume level when the power of this unit is turned on.

Choices: Off*, -80 dB to +16 dB

Control step: 1 dB

Note

- The “MAX VOL.” setting takes priority over the “INI.VOL.” setting.

2 INPUT MENU

Use this menu to reassign the input jacks, select the input mode or rename the input source.



- Initial settings are indicated by (*) in this following each parameter.

Input assignment A\INPUT ASSIGN

Use this feature to assign the input jacks according to the component to be used if the initial settings of this unit do not correspond to your needs.

Choices: CD, MD/CD-R, DVD, DTV/CBL, V-AUX, DVR

Initial setting:

IN (1) (COAXIAL jack): DVD

IN (2) (OPTICAL (DTV/CBL) jack): DTV/CBL

IN (3) (OPTICAL (CD) jack): CD

Notes

- You cannot select a specific item more than once.
- You cannot assign the same input source to both “IN (2)” and “IN (3).” For example, you assign “CD” to “IN (2),” “----” appears in “IN (3).”
- Once the input jacks are reassigned, you can select the corresponding component by using **INPUT** </> (or the input selector buttons (5) on the remote control).

Input rename B)INPUT RENAME

Use this feature to change the name of the input source that appears on the front panel display.

The following is an example where “DVD” is renamed “My DVD.”



- 1 Press one of the input selector buttons (5) or 6 MULTI CH IN to select the input source you want to change the name of.
- 2 Press 15 </> on the remote control to place the “_” (underscore) under the space or the character you want to edit.
- 3 Press 15 Δ / ▽ to select the character you want to use and then press 15 </> to move to the next space.

Notes

- You can use up to 8 characters for each input.
- Press 15 ▽ to change the character in the following order, or press 15 Δ to go in the reverse order:
A to Z, a space, 0 to 9, a space, a to z, a space, symbols (#, *, -, +, etc.)

- 4 Repeat steps 1 through 3 to rename each input source.
- 5 Press 11 MENU to exit from “INPUT RENAME.”

Volume trim C)VOLUME TRIM

Use this feature to adjust the level of the signal input at each jack. This is useful if you want to balance the level of each input source to avoid sudden changes in volume when switching between input sources.

Press one of the input selector buttons (5) or 22 MULTI CH IN to select the input source you want to adjust the level.

Choices: CD, TUNER, MD/CD-R, DVD, DTV/CBL, V-AUX, DVR, MULTI CH IN

Control range: -6.0 dB to 0.0 dB* to +6.0 dB

Control step: 1.0 dB

Decoder mode D)DECODER MODE**Decoder select mode**

Use this feature to designate the default decoder mode for the input sources connected to the DIGITAL INPUT jacks.

Choice	Function
AUTO*	Automatically detect the type of input signals and selects the appropriate decoder mode.
LAST	Automatically select the last decoder mode used the connected input source.

DTS decoder prioritize setting

Choice	Function
AUTO*	Automatically detect the type of input signals and selects the appropriate input mode.
DTS	Enables to playback a DTS-CD.

Multi channel input setup**E)MULTI CH SET****BGV** BGV

Use this feature to select the video source played in the background of the sources input from the MULTI CH INPUT jacks.

Choices: LAST*, DVR, V-AUX, DTV/CBL, DVD



- Select “LAST” to set this unit to automatically select the last selected video source as the background video source.

3 OPTION MENU

Use this menu to adjust the optional system parameters.



- Initial settings are indicated by (*) in this following each parameter.

Display settings A)DISPLAY SET**Dimmer** DIMMER

Use this feature to adjust the brightness of the front panel display.

Control range: -4 to 0*

Control step: 1

- Press 15 < to make the front panel display dimmer.
- Press 15 > to make the front panel display brighter.

Memory guard B)MEMORY GUARD**Memory guard** MEM.GUARD

Use this feature to prevent accidental changes to DSP program parameter values and other system settings.

Choice	Function
OFF*	Turns off the “MEM.GUARD” feature.
ON	Protects: <ul style="list-style-type: none"> - sound field program parameters - all set menu items - SCENE template parameters

Note

- When “MEM.GUARD” is set to “ON,” you cannot select and adjust any other set menu items.

Audio select C)AUDIO SELECT

Use this feature to designate the default audio input jack select setting for the input sources.

Choice	Function
AUTO*	Automatically detect the type of input signals and select the appropriate input mode.
LAST	Automatically select the last input mode used for the connected input source (see page 19).

Parameter initialization D)PARAM. INI

Use this feature to set all the parameters of the sound field programs to the initial factory settings.

Choice	Function
NO*	Cancels the parameter initialization and returns to the previous menu level.
YES	Sets all the sound field parameters to the initial factory settings.

Notes

- You cannot automatically revert to the previous parameter settings once you initialize the sound field program parameters.
- You cannot separately initialize individual sound field programs.

Advanced setup

This unit has additional menus that are displayed on the front panel display. The advanced setup menu offers additional operations to adjust and customize the way this unit operates. Change the initial settings (indicated by (*) in this following parameter) to reflect the needs of your listening environment.

Notes

- Only **STANDBY/ON**, **PROGRAM** $\triangleleft/\triangleright$ and **STRAIGHT** are effective while you are using the advanced setup menu.
- No other operations can be made while you are using the advanced setup menu.
- The advanced setup menu is only available on the front panel display.

1 Press **STANDBY/ON** on the front panel to set this unit to the standby mode.

2 Press and hold **TONE CONTROL** and then press **STANDBY/ON** to turn on this unit.

This unit turns on, and the advanced setup menu appears on the front panel display.

3 Press **PROGRAM** $\triangleleft/\triangleright$ to select the parameter you want to adjust.

The name of the selected parameter appears on the front panel display.

4 Press **STRAIGHT** repeatedly to change the selected parameter setting.

5 Press **STANDBY/ON** to confirm your selection and set this unit to the standby mode.



- The settings you made are reflected next time you turn on this unit.

■ Initializing PRESET

Use this feature to reset all the parameters of this unit to the initial factory settings.

Choices: CANCEL*, RESET

- Select “CANCEL” not to reset any parameters of this unit.
- Select “RESET” to reset the parameters of this unit.

Note

- The initial factory settings are activated next time you turn on this unit.

ADDITIONAL INFORMATION

Troubleshooting

Refer to the table below when this unit does not function properly. If the problem you are experiencing is not listed below or if the instruction below does not help, turn off this unit, disconnect the power cable, and contact the nearest authorized Yamaha dealer or service center.

■ General

Problem	Cause	Remedy	See page
This unit fails to turn on or enters the standby mode soon after the power is turned on.	The power cable is not connected or the plug is not completely inserted.	Connect the power cable firmly.	—
	The protection circuitry has been activated.	Make sure that all speaker wire connections on this unit and on all speakers are secure and that the wire for each connection does not touch anything other than its respective connection.	9
	This unit has been exposed to a strong external electric shock (such as lightning or strong static electricity).	Set this unit to the standby mode, disconnect the power cable, plug it back in after 30 seconds and then use it normally.	—
No sound	Incorrect input or output cable connections.	Connect the cables properly. If the problem persists, the cables may be defective.	11-13
	No appropriate Audio input jack select has been set.	Set an appropriate Audio input jack select.	36
	No appropriate input source has been selected.	Select an appropriate input source with ⓂINPUT <◁/▷ on the front panel (or the input selector buttons (5) on the remote control).	18, 19
	Speaker connections are not secure.	Secure the connections.	9
	The front speakers to be used have not been selected properly.	Select the front speakers with ⓄSPEAKERS .	19
	The volume is turned down.	Turn up the volume.	—
	The sound is muted.	Press 8 MUTE or 7 VOLUME +/- on the remote control to resume audio output and then adjust the volume.	20
	Signals this unit cannot reproduce are being input from a source component, such as a CD-ROM.	Play a source whose signals can be reproduced by this unit.	—
	Audio signals input at the HDMI jack are not output from any speaker terminals.	Make an analog or digital connection beside the HDMI connection.	—
	The setting of the connected component is improper.	Make an appropriate setting following the instruction manual of the connected component.	—
The sound suddenly goes off.	The protection circuitry has been activated because of a short circuit, etc.	Check that the speaker wires are not touching each other and then turn this unit back on.	—
	The sleep timer has turned off this unit.	Turn on this unit, and play the source again.	—
	The sound is muted.	Press 8 MUTE or 7 VOLUME +/- on the remote control to resume audio output.	20
Sound is heard from the speaker on one side only.	Incorrect cable connections.	Connect the cables properly. If the problem persists, the cables may be defective.	11-14
	Incorrect settings in “SP LEVEL.”	Adjust the “SP LEVEL” settings.	33

Problem	Cause	Remedy	See page
Only the center speaker outputs substantial sound.	When playing a monaural source with a CINEMA DSP program, the source signal is directed to the center channel, and the front and surround speakers output effect sounds.		
No sound is heard from the center speaker.	“CENTER” in “SPEAKER SET” is set to “NONE.”	Set “CENTER” to “SML” or “LRG.”	32
	Some sound field programs do not output sounds from the center speaker.	Try another sound field program.	25
No sound is heard from the surround speakers.	“SUR. LR” in “SPEAKER SET” is set to “NONE.”	Set “SUR. LR” to “SML” or “LRG.”	32
	This unit is in the “STRAIGHT” mode and a monaural source is being played back.	Press STRAIGHT on the front panel so that “STRAIGHT” disappears from the front panel display.	26
No sound is heard from the subwoofer.	“BASS OUT” in “SPEAKER SET” is set to “FRONT” when a Dolby Digital or DTS signal is being played.	Set “BASS OUT” to “SWFR” or “BOTH.”	32
	“BASS OUT” in “SPEAKER SET” is set to “SWFR” or “FRONT” when a 2-channel source is being played.	Set “BASS OUT” to “BOTH.”	32
	The source does not contain low-frequency bass signals.		
Dolby Digital or DTS sources cannot be played. (Dolby Digital or DTS indicator on the front panel display does not light up.)	The connected component is not set to output Dolby Digital or DTS digital signals.	Make an appropriate setting following the operating instructions for your component.	—
	Audio input jack select is set to “ANALOG.”	Set Audio input jack select to “AUTO.”	19
A humming sound is heard.	Incorrect cable connections.	Connect the audio cables firmly. If the problem persists, the cables may be defective.	—
The volume level cannot be increased, or the sound is distorted.	You are attempting to set the volume level higher than the maximum volume level.	Adjust “MAX VOL.” setting.	34
	The component connected to the AUDIO OUT (REC) jack on this unit is turned off.	Turn on the power of the component.	—
The sound effect cannot be recorded.	It is not possible to record the sound effect with a recording component.		
A source cannot be recorded by an analog component connected to the AUDIO OUT (REC) jack.	The source component is not connected to the analog AUDIO IN jacks on this unit.	Connect the source component to the analog AUDIO IN jacks.	13
The sound field parameters and some other settings of this unit cannot be changed.	“MEM.GUARD” in “OPTION MENU” is set to “ON.”	Set “MEM.GUARD” to “OFF.”	35

Problem	Cause	Remedy	See page
This unit does not operate properly.	The internal microcomputer has been frozen by an external electric shock (such as lightning or excessive static electricity) or by a power supply with low voltage.	Disconnect the power cable from the AC wall outlet and then plug it in again after about 30 seconds.	—
“CHECK SP WIRES” appears on the front panel display.	Speaker cables are short-circuited.	Make sure all speaker cables are connected correctly.	9
There is noise interference from digital or radio frequency equipment.	This unit is too close to the digital or high-frequency equipment.	Move this unit further away from such equipment.	—
The picture is disturbed.	The video source uses scrambled or encoded signals to prevent dubbing.		
This unit suddenly enters the standby mode.	The internal temperature is too high and the overheat protection circuitry has been activated.	Wait about 1 hour for this unit to cool down and then turn it back on.	—
Virtual CINEMA DSP is not activated.	“MULTI CH” is selected as the input source.	Select an input source other than “MULTI CH.”	18
	Headphones are connected to the PHONES jack.	Disconnect the headphone plug from the PHONES jack.	—
	This unit is in the “5ch Stereo” mode.	Exit from the “5ch Stereo” mode.	25
SILENT CINEMA is not activated.	“MULTI CH” is selected as the input source.	Select an input source other than “MULTI CH.”	18
	The unit is in the “2ch Stereo,” “STRAIGHT” or “Music Enh.2ch” mode.	Exit from the “2ch Stereo,” “STRAIGHT” or “Music Enh2ch” mode.	25

■ Tuner

Problem	Cause	Remedy	See page
FM stereo reception is noisy.	The characteristics of FM stereo broadcasts may cause this problem when the transmitter is too far away or the antenna input is poor.	Check the antenna connections.	15
		Try using a high-quality directional FM antenna.	—
		Use the manual tuning method.	27
There is distortion, and clear reception cannot be obtained even with a good FM antenna.	There is multi-path interference.	Adjust the antenna position to eliminate multi-path interference.	—
FM The desired station cannot be tuned into with the automatic tuning method.	The signal is too weak.	Use a high-quality directional FM antenna.	—
		Use the manual tuning method.	27
Previously preset stations can no longer be tuned into.	This unit has been disconnected for a long period.	Set preset stations.	27
“...WAIT” or “CT WAIT” appears on the front panel	The signal strength is weakened while this unit is receiving the Radio Data System data.	Check the antenna connections.	15
		Try using a high-quality directional FM antenna.	—
		Use the manual tuning method.	27

Problem	Cause	Remedy	See page
The desired station cannot be tuned into with the automatic tuning method.	The signal is weak or the antenna connections are loose.	Tighten the AM loop antenna connections and orient it for the best reception.	—
		Use the manual tuning method.	27
AM There are continuous crackling and hissing noises.	Noises result from lightning, fluorescent lamps, motors, thermostats and other electrical equipment.	Use an outdoor antenna and a ground wire. This will help somewhat, but it is difficult to eliminate all noise.	—
There are buzzing and whining noises.	A TV set is being used nearby.	Move this unit away from the TV set.	—

■ **AUTO SETUP**

Before AUTO SETUP

Error message	Cause	Remedy	See page
Connect MIC!	Optimizer microphone is not connected.	Connect the supplied optimizer microphone to the OPTIMIZER MIC jack on the front panel.	16
Unplug HP!	Headphones are connected.	Unplug the headphones.	—

During AUTO SETUP

Error message	Cause	Remedy	See page
NO FRONT L SP NO FRONT R SP	Front L/R channel signals are not detected.	Check the front L/R speaker connections.	9
NO SUR. L SP NO SUR. R SP	A surround channel signal is not detected.	Check the surround speaker connections.	9
NOISY	Background noise is too loud.	Try running "AUTO SETUP" in a quiet environment.	—
		Turn off noisy electric equipment like air conditioners or move them away from the optimizer microphone.	—
NO MIC	The optimizer microphone was unplugged during the "AUTO SETUP" procedure.	Connect the supplied optimizer microphone to OPTIMIZER MIC jack on the front panel.	16
USER CANCEL	The "AUTO SETUP" procedure was cancelled due to user activity.	Run "AUTO SETUP" again.	16

After AUTO SETUP

Warning message	Cause	Remedy	See page
PHASE REVERSED	Speaker polarity is not correct. This message may appear depending on the speakers even when the speakers are connected correctly.	Check the speaker connections for proper polarity (+ or -).	9
DISTANCE ERROR	The distance between the nearest speaker and the furthest speaker is out of adjustable range.	Bring the speaker closer to the listening position.	—
LEVEL ERROR	The difference of volume level among speakers is excessive. (No level correction is made.)	If “SWFR:TOO LOUD” or “SWFR:TOO LOW” appears, adjust the output volume of the subwoofer.	16
		Readjust the speaker installation so that all speakers are set in locations with similar conditions.	—
		Check the speaker connections.	9
		Use speakers of similar quality.	—

Notes

- If the “ERROR” or “WARNING” screens appears, check the cause of the problem, then run “AUTO SETUP” again.
- If a warning message “PHASE REVERSED” appears, corrections are made, but they may not be optimal.
- If a warning message “DISTANCE ERROR” or “LEVEL ERROR” appears, no corrections are made.

■ Remote control

Problem	Cause	Remedy	See page
The remote control does not work nor function properly.	Wrong distance or angle.	The remote control functions within a maximum range of 6 m (20 ft) and no more than 30 degrees off-axis from the front panel.	8
	Direct sunlight or lighting (from an inverter type of fluorescent lamp, etc.) is striking the remote control sensor of this unit.	Reposition this unit.	—
	The batteries are weak.	Replace all batteries.	8
	Even if the remote control code is correctly set, there are some models that do not respond to the remote control.		

■ Resetting the system

Use this feature to reset all the parameters of this unit to the initial factory settings. For details about the procedure of resetting the system, see “Initializing” in “Advanced setup” on page 37.

■ Audio information

Dolby Digital

Dolby Digital is a digital surround sound system that gives you completely independent multi-channel audio. With 3 front channels (front L/R and center), and 2 surround stereo channels, Dolby Digital provides 5 full-range audio channels. With an additional channel especially for bass effects, called LFE (Low Frequency Effect), the system has a total of 5.1-channels (LFE is counted as 0.1 channel). By using 2-channel stereo for the surround speakers, more accurate moving sound effects and surround sound environment are possible than with Dolby Surround. The wide dynamic range from maximum to minimum volume reproduced by the 5 full-range channels and the precise sound orientation generated using digital sound processing provide listeners with unprecedented excitement and realism. With this unit, any sound environment from monaural up to a 5.1-channel configuration can be freely selected for your enjoyment.

Dolby Pro Logic II

Dolby Pro Logic II is an improved technique used to decode vast numbers of existing Dolby Surround sources. This new technology enables a discrete 5-channel playback with 2 front left and right channels, 1 center channel, and 2 surround left and right channels instead of only 1 surround channel for conventional Pro Logic technology. There are three modes available: "Music mode" for music sources, "Movie mode" for movie sources and "Game mode" for game sources.

Dolby Surround

Dolby Surround uses a 4-channel analog recording system to reproduce realistic and dynamic sound effects: 2 front left and right channels (stereo), a center channel for dialog (monaural), and a surround channel for special sound effects (monaural). The surround channel reproduces sound within a narrow frequency range. Dolby Surround is widely used with nearly all video tapes and laser discs, and in many TV and cable broadcasts as well. The Dolby Pro Logic decoder built into this unit employs a digital signal processing system that automatically stabilizes the volume on each channel to enhance moving sound effects and directionality.

DTS Digital Surround

DTS digital surround was developed to replace the analog soundtracks of movies with a 5.1-channel digital sound track, and is now rapidly gaining popularity in movie theaters around the world. DTS, Inc. has developed a home theater system so that you can enjoy the depth of sound and natural spatial representation of DTS digital surround in your home. This system produces practically distortion-free 5.1-channel sound (technically, left, right and center channels, 2 surround channels, plus an LFE 0.1 channel as a subwoofer, for a total of 5.1-channels).

LFE 0.1 channel

This channel reproduces low-frequency bass signals. The frequency range of this channel is from 20 Hz to 120 Hz. This channel is counted as 0.1 because it only enforces a low-frequency range compared to the full-range reproduced by the other 5 channels in Dolby Digital or DTS 5.1-channel systems.

PCM (Linear PCM)

Linear PCM is a signal format under which an analog audio signal is digitized, recorded and transmitted without using any compression. This is used as a method of recording CDs and DVD audio. The PCM system uses a technique for sampling the size of the analog signal per very small unit of time. Standing for "Pulse Code Modulation," the analog signal is encoded as pulses and then modulated for recording.

■ Sampling frequency and number of quantized bits

When digitizing an analog audio signal, the number of times the signal is sampled per second is called the sampling frequency, while the degree of fineness when converting the sound level into a numeric value is called the number of quantized bits. The range of rates that can be played back is determined based on the sampling rate, while the dynamic range representing the sound level difference is determined by the number of quantized bits. In principle, the higher the sampling frequency, the wider the range of frequencies that can be played back, and the higher the number of quantized bits, the more finely the sound level can be reproduced.

■ Sound field program information

CINEMA DSP

Since the Dolby Surround and DTS systems were originally designed for use in movie theaters, their effect is best felt in a theater having many speakers designed for acoustic effects. Since home conditions, such as room size, wall material, number of speakers, and so on, can differ so widely, it is inevitable that there are differences in the sound heard. Based on a wealth of actually measured data, Yamaha CINEMA DSP uses Yamaha original DSP technology to combine Dolby Pro Logic, Dolby Digital and DTS systems to provide the audiovisual experience of movie theater in the listening room of your own home.

SILENT CINEMA

Yamaha has developed a natural, realistic sound effect DSP algorithm for headphones. Parameters for headphones have been set for each sound field program so that accurate representations of all the sound field programs can be enjoyed on headphones.

Virtual CINEMA DSP

Yamaha has developed a Virtual CINEMA DSP algorithm that allows you to enjoy DSP surround effects even without any surround speakers by using virtual surround speakers. It is even possible to enjoy Virtual CINEMA DSP using a minimal two-speaker system that does not include a center speaker.

■ Video information

Component video signal

With the component video signal system, the video signal is separated into the Y signal for the luminance and the PB and PR signals for the chrominance. Color can be reproduced more faithfully with this system because each of these signals is independent. The component signal is also called the "color difference signal" because the luminance signal is subtracted from the color signal. A monitor with component input jacks is required in order to output component signals.

Composite video signal

With the composite video signal system, the video signal is composed of three basic elements of a video picture: color, brightness and synchronization data. A composite video jack on a video component transmits these three elements combined.

Specifications

AUDIO SECTION

- Minimum RMS Output Power for Front, Center, Surround
1 kHz, 0.9% THD, 6 Ω 100 W/ch
- Maximum Power (JEITA)
1 kHz, 10% THD, 6 Ω 135 W/ch
- MAX Power Per Channel
1 kHz, 0.7% THD, 4 Ω 105 W or more
- IEC Power
1 kHz, 0.1% THD, 6 Ω 90 W or more
- Dynamic Power
(IHF, 6/4/2 Ω) 105/130/150 W
- Dynamic Headroom
8 Ω 0.41 dB
- Frequency Response
CD, etc. to Front 10 Hz to 100 kHz, 0/-3 dB
V-AUX to Front 10 Hz to 20 kHz, 0/-3 dB
- Total Harmonic Distortion
CD, etc. (2ch stereo) to Front SP OUT,
1 kHz, 50 W/6 Ω 0.06% or less
- Signal to Noise Ratio (IHF-A Network)
CD, etc. (STEREO) Input shorted
250 mV 100 dB or more
200 mV 98 dB or more
- Residual Noise (IHF-A Network)
Front L/R 170 μV or less
- Channel Separation
CD, etc. Input 5.1 kΩ shorted (1 kHz/10 kHz)
..... 60 dB/45 dB or more
- Tone Control
BASS Boost/Cut ±10 dB/100 Hz
TREBLE Boost/Cut ±10 dB/20 kHz
- Headphone Jack Rated Output/Impedance
CD, etc. (1 kHz, 200 mV, 8 Ω) 0.4 V/470 Ω
- Input Sensitivity/Input Impedance
CD, etc. 200 mV/47 kΩ
MULTI CH INPUT 200 mV/47 kΩ
- Maximum Input Signal
CD, etc. 1 kHz, 0.5%THD (EFFECT ON) 2.0 V or more

- Output Level/Output Impedance
AUDIO OUT (REC) 200 mV/1.2 kΩ
SUBWOOFER OUTPUT
(2ch Stereo and FRONT SP: SMALL) 4 V/1.2 kΩ
- Filter Characteristics (fc=40/60/80/90/100/110/120/160/200 Hz)
H.P.F. (Front, Center, Surround) 12 dB/oct.
L.P.F. (Subwoofer) 24 dB/oct.

VIDEO SECTION

- Signal Level
Composite 1 Vp-p/75 Ω
Component 1 Vp-p/75 Ω (Y), 0.7 Vp-p/75 Ω (PB/PR)
- Video Maximum Input Level 1.5 Vp-p or more
- Signal to Noise Ratio 50 dB or more
- Frequency Response (MONITOR OUT)
Component Signal 5 Hz to 60 MHz, -3 dB

FM SECTION

- Tuning Range 87.50 to 108.00 MHz
- 50 dB Quieting Sensitivity (IHF, 100% mod.)
Mono 2.8 μV (20.2 dBf)
- Signal to Noise Ratio (IHF)
Mono/Stereo 73 dB/70 dB
- Harmonic Distortion (1 kHz)
Mono/Stereo 0.5%/0.5%

AM SECTION

- Tuning Range 531 to 1611 kHz

GENERAL

- Power Supply 230 V AC, 50 Hz
- Power Consumption 240 W
- Standby Power Consumption 0.8 W
- Dimensions (W x H x D) 435 x 151 x 318 mm
(17-1/8" x 5-15/16" x 12-1/2")
- Weight 8.0 kg (17 lbs 10 oz)

* Specifications are subject to change without notice.

Index

■ Numerics

1 SOUND MENU	31, 32
2 INPUT MENU	31, 34
2ch Stereo	25
3 OPTION MENU	31, 35
5ch Stereo	25

■ A

A)DISPLAY SET	35
A)INPUT ASSIGN	34
A)SPEAKER SET	32
A.DELAY	34
A/B/C/D/E, front panel	3
Adjusting the speaker level	20
Adjusting the tonal quality	20
AFFAIRS, Radio Data System program type	29
AM tuning	27
ANTENNA terminals	6
Audio cable plugs	11
Audio delay	34
AUDIO jacks	6, 11
Audio jacks	11
AUDIO L/R (VIDEO AUX) jacks, front panel	3
AUDIO SEL, remote control	5
AUDIO SELECT	19
Audio select	36
Audio settings	34
AUTO SETUP	16, 31
Auto setup	31
AUTO SETUP, Error message	41
Automatic preset tuning	27
Automatic tuning	27

■ B

B)INPUT RENAME	35
B)MEMORY GUARD	35
B)SP LEVEL	33
BAND, front panel	3
BASS OUT	32
BGV	35

■ C

C)AUDIO SELECT	36
C)SP DISTANCE	33
C)VOLUME TRIM	35
CD Listening	23
CD Music Listening	23
CENTER	32
Center graphic equalizer	33
Center speaker	32
Center width	26
CINEMA DSP indicator	4
CLASSICS, Radio Data System program type	29
Clock time, Radio Data System information	29
COMPONENT VIDEO jacks	6, 11
Connect MIC!, Auto setup error message	41
Connecting a DVD player	13
Connecting a TV	12
Connecting audio components	13
Connecting speakers	9
Connecting the AM antennas	15
Connecting the FM antennas	15
Connecting the power cable	15
Connecting to CD player	13
Connecting to DVD recorder	13
Connecting to MD recorder/CD recorder	13
Connecting to the CENTER terminals	10
Connecting to the COMPONENT VIDEO jacks	11
Connecting to the FRONT A terminals	10
Connecting to the FRONT B terminals	10
Connecting to the HDMI jacks	11

Connecting to the MULTI CH INPUT

jacks	14
Connecting to the SURROUND terminals	10
Connecting video components	13
Creating original SCENE templates	24
CROSSOVER	33
Crossover	33
CT WIDTH	26
CT, Radio Data System information	29
CULTURE, Radio Data System program type	29
Cursors/ENTER, remote control	5

■ D

D)CENTER GEO	33
D)DECODER MODE	35
D)PARAM. INI	36
Decoder indicator	4
Decoder mode	35
Decoder select mode	35
DIGITAL AUDIO COAXIAL jack	11
DIGITAL AUDIO OPTICAL jacks	11
DIGITAL INPUT COAXIAL assignment	34
DIGITAL INPUT jacks	6
DIMENSION	26
Dimension	26
DIMMER	35
Dimmer	35
Disc Listening	23
Display settings	35
DISPLAY, remote control	5
DISTANCE ERROR, Auto setup error message	42
DRAMA, Radio Data System program type	29
DSP LEVEL	26
DSP level	26
DTS decoder prioritize setting	35
DVD Live Viewing	23
DVD Movie Viewing	23
DVD Viewing	23
DVR Viewing	23
Dynamic range	34

■ E

E)LFE LEVEL	34
E)MULTI CH SET	35
EDIT PRESET/TUNING, front panel	3
Editing sound field parameters	26
EDUCATE, Radio Data System program type	29
Enhanced other networks data service, Radio Data System tuning	30
ENHANCER indicator	4
ENHANCER, remote control	5
Enjoying 2-channel sources using the standard decoders	26
EON	4
EON data service, Radio Data System tuning	30
EON, Radio Data System information	29
Exchanging preset stations	28

■ F

F)D.RANGE	34
FM tuning	27
FRONT	32
FRONT B	32
FRONT B speaker setting	32
Front panel	3
Front panel display	3, 4
Front speakers	32

■ G

G)AUDIO SET	34
Game Playing	23

■ H

Hall	25
HDMI	11
HDMI jack, HDMI cable plug	11
HDMI terminals	6
Headphone dynamic range	34
Headphone LFE	34
Headphones indicator	4
HP D.R	34
HP LFE	34

■ I

INFO, Radio Data System program type	29
INFO/Radio data system control, remote control	5
Infrared window	8
Infrared window, remote control	5
INI.VOL.	34
Initial volume	34
Initializing	37
Input assignment	34
Input channel and speaker indicators	4
Input channel indicators	4
Input menu	31
Input rename	35
Input selector buttons, remote control	5
Input source indicators	4
Input source information	21
INPUT, front panel	3
Installing batteries in the remote control	8

■ J

Jazz	25
------------	----

■ L

LEVEL ERROR, Auto setup error message	42
LEVEL, remote control	5
LFE indicator	4
LFE/Bass out	32
LIGHT M, Radio Data System program type	29
Listening to unprocessed input signals	26
Low-frequency effect level	34

■ M

M.O.R. M, Radio Data System program type	29
Manual preset tuning	28
MANUAL SETUP	31
Manual setup	31
Manual tuning	27
MAX VOL.	34
Maximum volume	34
MEM.GUARD	35
Memory guard	35
MEMORY, front panel	3
MENU, remote control	5
Movie Dramatic	25
Movie Spacious	25
MULTI CH IN, remote control	5
MULTI CH INPUT jacks	6
Multi channel input setup	35
Multi-channel sources and sound field programs with headphones	26
Multi-information display	4
Music Disc Listening	23
Music Enh. 2ch	25
Music Enh. 5ch	25
MUTE indicator	4
MUTE TYP.	34
Mute type	34
MUTE, remote control	5
Muting the audio output	20

■ N

NEWS, Radio Data System program type	29
NIGHT indicator	4
Night listening mode	20
NIGHT, front panel	3
NIGHT, remote control	5
NO FRONT L SP, Auto setup error message	41
NO FRONT R SP, Auto setup error message	41
NO MIC, Auto setup error message	41
NO SUR.L SP, Auto setup error message	41
NO SUR.R SP, Auto setup error message	41
NOISY, Auto setup error message	41

■ O

OPTIMIZER MIC jack, Auto setup	16
OPTIMIZER MIC jack, front panel	3
Optimizer microphone	16
Optimizer microphone, Auto setup	16
Optimizing speaker setting	16
Option menu	31
OTHER M, Radio Data System program type	29

■ P

PANORAMA	26
Panorama	26
Parameter initialization	36
PCM indicator	4
PHASE REVERSED, Auto setup error message	42
PHONES jack, front panel	3
Placing speakers	9
Playing video sources in the background	21
POP M, Radio Data System program type	29
Pop/Rock	25
PORTABLE (VIDEO AUX) jack, front panel	3
Power cable	6
POWER, remote control	5
PRESET	37
Preset SCENE templates	23
PRESET/TUNING, front panel	3
PROG, remote control	5
Program service, Radio Data System information	29
Program type, Radio Data System information	29
PROGRAM, front panel	3
PS, PTY, RT and CT	4
PTY HOLD PTY SEEK mode, Radio Data System tuning	29
PTY, Radio Data System information	29

■ R

Radio Data System indicators	4
Radio Data System tuning	29
Radio Listening	23
Radio text, Radio Data System information	29
Rear panel	6
Remote control	5
Resetting the system	37
RETURN, remote control	5
ROCK M, Radio Data System program type	29
RT, Radio Data System information	29

■ S

SCENE	22
SCENE 1/2/3/4, front panel	3
SCENE 1/2/3/4, remote control	5
SCIENCE, Radio Data System program type	29
Selecting audio input jacks	19
Selecting preset stations	28

Selecting the MULTI CH INPUT component as the input source	19
Selecting the night listening mode	20
Selecting the SCENE templates	22
Selection, Radio Data System program type	29
Set menu	31
Set this unit to the standby mode	15
SIGNAL INFO	21
Signal information	31
SILENT CINEMA	26
SILENT CINEMA indicator	4
SLEEP indicator	4
Sleep timer	21
SLEEP, remote control	5
Sound field programs	25
Sound menu	31
SP A B indicators	4
SP D.R	34
SP LFE	34
Speaker distance	33
Speaker distances	33
Speaker dynamic range	34
Speaker level	33
Speaker LFE	34
Speaker settings	32
SPEAKERS terminals	6
SPEAKERS, front panel	3
Specifications	44
SPORT, Radio Data System program type	29
STANDBY, remote control	5
STANDBY/ON, front panel	3
Straight decoding mode	26
STRAIGHT, front panel	3
STRAIGHT, remote control	5
SUBWOOFER OUTPUT jack	6
Subwoofer phase	33
Supplied accessories	2
SUR. LR	32
SUR.DECODE, remote control	5
Surround left/right speakers	32
SWFR PHASE	33

■ T

TEST	34
Test tone	34
TONE CONTROL, front panel	3
Troubleshooting	38
Tuner indicators	4
TUNING AUTO/MAN'L, front panel	3
Turning off the power	15
Turning on the power	15
TV Sports	25
TV Sports Viewing	23
TV Viewing	23

■ U

UNIT	33
Unit	33
Unplug HP!, Auto setup error message	41
USER CANCEL, Auto setup error message	41
Using the remote control	8
Using the VIDEO AUX jacks	14
Using your headphones	20

■ V

VARIED, Radio Data System program type	29
VIDEO (VIDEO AUX) jack, front panel	3
Video cable plugs	11
VIDEO jacks	6, 11
Video jacks	11
Virtual CINEMA DSP	26
VIRTUAL indicator	4
VOLUME +/-, remote control	5
VOLUME control, front panel	3
VOLUME level indicator	4
Volume Trim	35

■ Y

Yamaha Parametric Room Acoustic Optimizer	16
YPAO (Yamaha Parametric Room Acoustic Optimizer)	16
YPAO indicator	4

■ Z

Zone B	19
--------	----

“(A) **STANDBY/ON**” or “[5] **DVD**” (example) indicates the name of the parts on the front panel or the remote control. Refer to “Functional overview” on page 3.



© 2009 Yamaha Corporation All rights reserved.

YAMAHA CORPORATION
Printed in China © WQ95910