

# YAMAHA DSP-E200

*Natural Sound Digital Sound Field Processor*

*4 Programs for Digital Sound Field Processing*

*2 Programs for Dolby Surround (DOLBY PRO LOGIC and ENHANCED)*

*Center and Rear Channel Power Amplifier*

*25W (8Ω) RMS Output Power, 0.08% THD, 20-20,000 Hz (Center)*

*25W + 25W (8Ω) RMS Output Power, 0.3% THD, 1,000 Hz (Rear)*

*Automatic Input Balance Control for Dolby Surround*

*Test Tone Generator for Easier Speaker Output Balance Adjustment*

*3 Center Channel Modes*

*Remote Control Capability*

*Thank you for selecting this YAMAHA digital sound field processor.*



## OWNER'S MANUAL

### CONTENTS

Safety Instructions.....	2
Warning .....	3
Supplied Accessories .....	3
Profile of This Unit .....	4
Speaker Configurations for This Unit .....	5
Connections .....	6
Identification of Controls .....	10
Adjustment Before Operation .....	11
Using Digital Sound Field Processor (DSP) .....	13
Notes about the Remote Control .....	
Transmitter .....	17
Specifications .....	17
Troubleshooting.....	18

#### IMPORTANT!

Please record the serial number of this unit in the space below.

Model:  
Serial No.:

The serial number is located on the rear of the unit.  
Retain this Owner's Manual in a safe place for future reference.

#### WARNING

TO REDUCE THE RISK OF FIRE OR ELECTRIC SHOCK, DO NOT EXPOSE THIS UNIT TO RAIN OR MOISTURE.

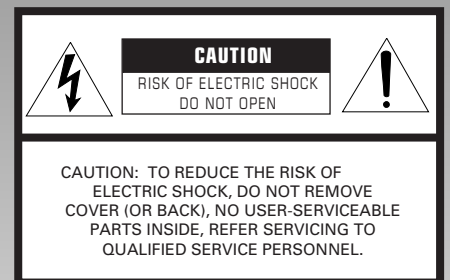

#### • Explanation of Graphical Symbols



The lightning flash with arrowhead symbol, within an equilateral triangle, is intended to alert you to the presence of uninsulated "dangerous voltage" within the product's enclosure that may be of sufficient magnitude to constitute a risk of electric shock to persons.



The exclamation point within an equilateral triangle is intended to alert you to the presence of important operating and maintenance (servicing) instructions in the literature accompanying the appliance.

# SAFETY INSTRUCTIONS

- 1 Read Instructions – All the safety and operating instructions should be read before the unit is operated.
- 2 Retain Instructions – The safety and operating instructions should be retained for future reference.
- 3 Heed Warnings – All warnings on the unit and in the operating instructions should be adhered to.
- 4 Follow Instructions – All operating and other instructions should be followed.
- 5 Water and Moisture – The unit should not be used near water – for example, near a bathtub, washbowl, kitchen sink, laundry tub, in a wet basement, or near a swimming pool, etc.
- 6 Carts and Stands – The unit should be used only with a cart or stand that is recommended by the manufacturer.
- 6A A unit and cart combination should be moved with care. Quick stops, excessive force, and uneven surfaces may cause the unit and cart combination to overturn.
- 7 Wall or Ceiling Mounting – The unit should be mounted to a wall or ceiling only as recommended by the manufacturer.
- 8 Ventilation – The unit should be situated so that its location or position does not interfere with its proper ventilation. For example, the unit should not be situated on a bed, sofa, rug, or similar surface, that may block the ventilation openings; or placed in a built-in installation, such as a bookcase or cabinet that may impede the flow of air through the ventilation openings.
- 9 Heat – The unit should be situated away from heat sources such as radiators, stoves, or other appliances that produce heat.
- 10 Power Sources – The unit should be connected to a power supply only of the type described in the operating instructions or as marked on the unit.
- 11 Power-Cord Protection – Power-supply cords should be routed so that they are not likely to be walked on or pinched by items placed upon or against them, paying particular attention to cords at plugs, convenience receptacles, and the point where they exit from the unit.
- 12 Cleaning – The unit should be cleaned only as recommended by the manufacturer.
- 13 Nonuse Periods – The power cord of the unit should be unplugged from the outlet when left unused for a long period of time.
- 14 Object and Liquid Entry – Care should be taken so that objects do not fall into and liquids are not spilled into the inside of the unit.
- 15 Damage Requiring Service – The unit should be serviced by qualified service personnel when:
  - A. The power-supply cord or the plug has been damaged; or
  - B. Objects have fallen, or liquid has been spilled into the unit; or
  - C. The unit has been exposed to rain; or
  - D. The unit does not appear to operate normally or exhibits a marked change in performance; or
  - E. The unit has been dropped, or the cabinet damaged.
- 16 Servicing – The user should not attempt to service the unit beyond those means described in the operating instructions. All other servicing should be referred to qualified service personnel.
- 17 Power Lines – An outdoor antenna should be located away from power lines.
- 18 Grounding or Polarization – Precautions should be taken so that the grounding or polarization is not defeated.



## FCC INFORMATION

### 1. IMPORTANT NOTICE : DO NOT MODIFY THIS UNIT!

This product, when installed as indicated in the instructions contained in this manual, meets FCC requirements. Modifications not expressly approved by Yamaha may void your authority, granted by the FCC, to use the product.

**2. IMPORTANT :** When connecting this product to accessories and/or another product use only high quality shielded cables. Cable/s supplied with this product MUST be used. Follow all installation instructions. Failure to follow instructions could void your FCC authorization to use this product in the USA.

**3. NOTE :** This product has been tested and found to comply with the requirements listed in FCC Regulations, Part 15 for Class "B" digital devices. Compliance with these requirements provides a reasonable level of assurance that your use of this product in a residential environment will not result in harmful interference with other electronic devices.

This equipment generates/uses radio frequencies and, if not installed and used according to the instructions found in the users manual, may cause interference harmful to the operation of other electronic devices.

Compliance with FCC regulations does not guarantee that interference will not occur in all installations. If this product is found to be the source of interference, which can be determined by turning the unit "OFF" and "ON", please try to eliminate the problem by using one of the following measures:

Relocate either this product or the device that is being affected by the interference.

Utilize power outlets that are on different branch (circuit breaker or fuse) circuits or install AC line filter/s.

In the case of radio or TV interference, relocate/reorient the antenna. If the antenna lead-in is 300 ohm ribbon lead, change the lead-in to co-axial type cable.

If these corrective measures do not produce satisfactory results, please contact the local retailer authorized to distribute this type of product. If you can not locate the appropriate retailer, please contact Yamaha Electronics Corp., U.S.A. 6660 Orangethorpe Ave, Buena Park, CA 90620.

The above statements apply ONLY to those products distributed by Yamaha Corporation of America or its subsidiaries.

## CAUTION: READ THIS BEFORE OPERATING YOUR UNIT

- 1 To ensure the finest performance, please read this manual carefully. Keep it in a safe place for future reference.
- 2 Install your unit in a cool, dry, clean place – away from windows, heat sources, and too much vibration, dust, moisture or cold. Avoid sources of hum (transformers, motors). To prevent fire or electrical shock, do not expose to rain and water.
- 3 Do not operate the unit upside-down. It may overheat, possibly causing damage.
- 4 Never open the cabinet. If a foreign object drops into the set, contact your dealer.
- 5 Do not place records or other objects on top of the unit; this will block the ventilation holes, cause the internal temperature to rise and may result in a failure.
- 6 Do not use force on switches, knobs or cords. When moving the set, first turn the unit off. Then gently disconnect the power plug and the cords connecting to other equipment. Never pull the cord itself.
- 7 Do not attempt to clean the unit with chemical solvents; this might damage the finish. Use a clean, dry cloth.
- 8 Be sure to read the “Troubleshooting” section on common operating errors before concluding that your unit is faulty.
- 9 Do not connect audio equipment to the AC outlets on the rear panel if that equipment requires more power than the outlets are rated to provide.

## We Want You Listening For A Lifetime

YAMAHA and the Electronic Industries Association's Consumer Electronics Group want you to get the most out of your equipment by playing it at a safe level. One that lets the sound come through loud and clear without annoying blaring or distortion – and, most importantly, without affecting your sensitive hearing. Since hearing damage from loud sounds is

often undetectable until it is too late, YAMAHA and the Electronic Industries Association's Consumer Electronics Group recommend you to avoid prolonged exposure from excessive volume levels.



## SUPPLIED ACCESSORIES

After unpacking, check that the following parts are contained.

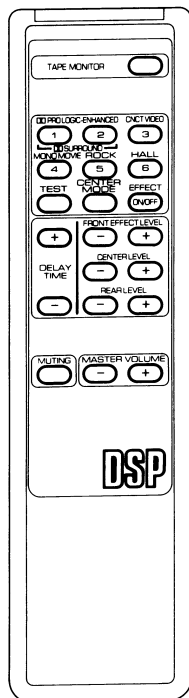

Remote Control Transmitter

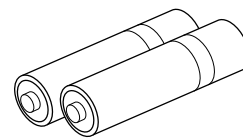

Batteries (size AA, LR6, AM-3)

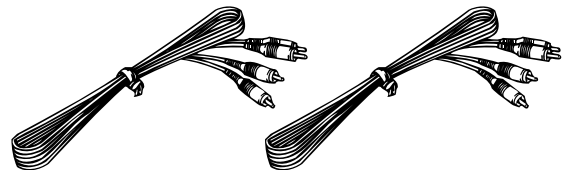

Audio Connection Cord x 2

# PROFILE OF THIS UNIT

You are the proud owner of Yamaha DSP-E200 –an extremely sophisticated audio component. The Digital Sound Field Processor (DSP) built in this unit takes full advantage of Yamaha's undisputed leadership in the field of digital audio processing to bring you a whole new world of listening experiences. Follow the instructions in this manual carefully when setting up your system, and this unit will sonically transform your room into a wide range of listening environments –movie theater, concert hall, and so on. In addition, you get incredible realism from Dolby-encoded video sources using the built-in Dolby Pro Logic Surround Decoder. Rather than tell you about the wonders of digital sound field processing, however, let's get right down to the business of setting up the system and trying out its many capabilities. Please read this operation manual carefully and store it in a safe place for later reference.

## Digital Sound Field Processing

---

What is it that makes live music so good? Today's advanced sound reproduction technology lets you get extremely close to the sound of a live performance, but chances are you'll still notice something missing: the acoustic environment of the live concert hall. Extensive research into the exact nature of the sonic reflections that create the ambience of a large hall has made it possible for Yamaha engineers to bring you this same sound in your own listening room, so you'll feel all the sound of a live concert.

What's more, our technicians, armed with sophisticated measuring equipment, have even made it possible to capture the acoustics of a variety of actual concert hall, theater, etc. to allow you to accurately recreate one of several actual live performance environments, all in your own home.

## Dolby Pro Logic Surround

---

The Dolby Pro Logic Surround Decoder program lets you experience the dramatic realism and impact of Dolby Surround movie theater sound in your own home. Dolby Pro Logic gets its name from its professional-grade steering logic circuitry, which provides greater effective channel separation for a much higher degree of realism than the "passive" Dolby Surround circuits found in today's typical home audio/video equipment. Dolby Pro Logic Surround provides a true center channel, so that there are four independent channels, unlike passive Dolby Surround which has in effect only three channels: left, right, and rear. This center channel allows listeners seated in even less-than-ideal positions to hear the dialog originating from action on the screen while getting a stereo effect as well.

This Dolby Pro Logic Surround Decoder employs a digital signal processing system. This system increases sound stability at each channel and minimizes crosstalk between channels, compared to conventional analog Dolby signal processing. In addition, this unit features a built-in automatic input balance control. This circuit always presents you the best surround conditions without performing manual adjustments.

## "ENHANCED" Dolby Pro Logic Surround

---

This unit has a second mode of Dolby Pro Logic Surround processing called "Enhanced Dolby Pro Logic Surround" processing. Enhanced Dolby Pro Logic Surround processing recreates the surround effect of a movie theater, effectively duplicating their multiple surround loudspeaker system, completely surrounding the listener with the sounds of the action taking place on the screen.

# SPEAKER CONFIGURATIONS FOR THIS UNIT

## SPEAKERS TO BE USED

This unit is designed to provide the best sound-field quality with 5 speaker configuration. The speakers to be used with this unit will be mainly front speakers, rear speakers, and a center speaker. (You can delete a center speaker. Refer to the “4-Speaker Configuration” shown below.)

The front speakers are used for the output of the main source sound and the effect sound. They will probably be your present stereo speaker system. The rear speakers are used for the output of the effect sound. And the center speaker is used for the output of the center sound (dialogue etc.) encoded with the Dolby Surround. The rear and center speakers do not need to be equal with the front speakers. However, all the speakers should have high enough power handling to accept the maximum output of this unit that will drive them.

## SPEAKER CONFIGURATION

### 5-Speaker Configuration

This configuration is the most effective and recommended. In this configuration, the center speaker is necessary as well as the rear speakers. If the digital sound field program is in the **DOLBY PRO LOGIC** or **ENHANCED**, conversations will be output from the center speaker and the ambience will be excellent.

\* Set the center mode to the “**NORMAL**” or “**WIDE**” position. (For details, refer to the page 11.)

### 4-Speaker Configuration

The center speaker is not used in this configuration. If the digital sound field program is in the **DOLBY PRO LOGIC** or **ENHANCED**, the center sound is output from the left and the right front speakers. However, the sound effect of other programs can be the same as that of the 5-speaker configuration.

\* Be sure to set the center mode to the “**PHANTOM**” position. (For details, refer to the page 11.)

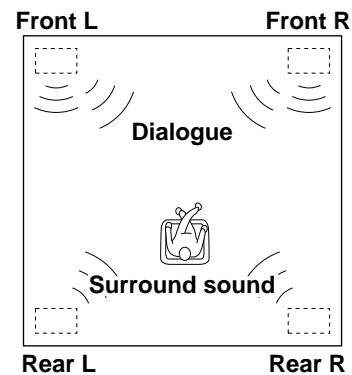
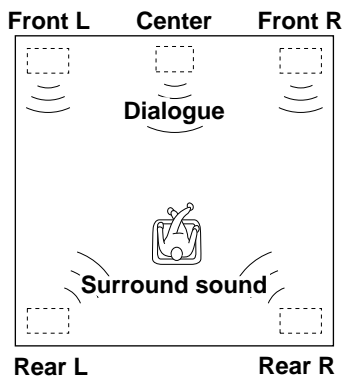

## SPEAKER PLACEMENT

The recommended speaker configuration, the 5-speaker configuration, will require two speaker pairs: **front speakers** (your normal stereo speakers), and **rear speakers**, plus a **center speaker**. When you place these speakers, refer to the following.

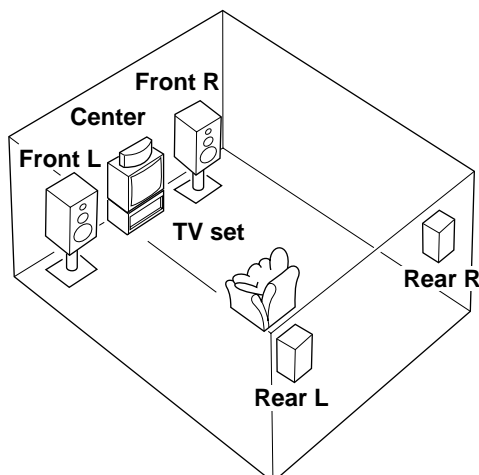

**Front:** In normal position. (The position of your present stereo speaker system.)

**Rear:** Behind your listening position, facing slightly inward. Nearly six feet up from the floor.

**Center:** Precisely between the front speakers. (To avoid interference to TV sets, use a magnetically shielded speaker. If, however, it is not effective, keep the speaker away from TV sets.)

# CONNECTIONS

- Before attempting to make any connections to or from this unit, be sure to first switch OFF the power to this unit and to any other components to which connections are being made.
- When making connections between this unit and other components, be sure all connections are made correctly, that is to say L (left) to L, R (right) to R, “+” to “+” and “-” to “-”. Also, refer to the owner’s manual for each component to be connected to this unit.
- Choose one of the following three ways to connect this unit to your amplifier.

## A Connecting to an Integrated Amplifier or Stereo Receiver with PRE OUT and MAIN IN terminals

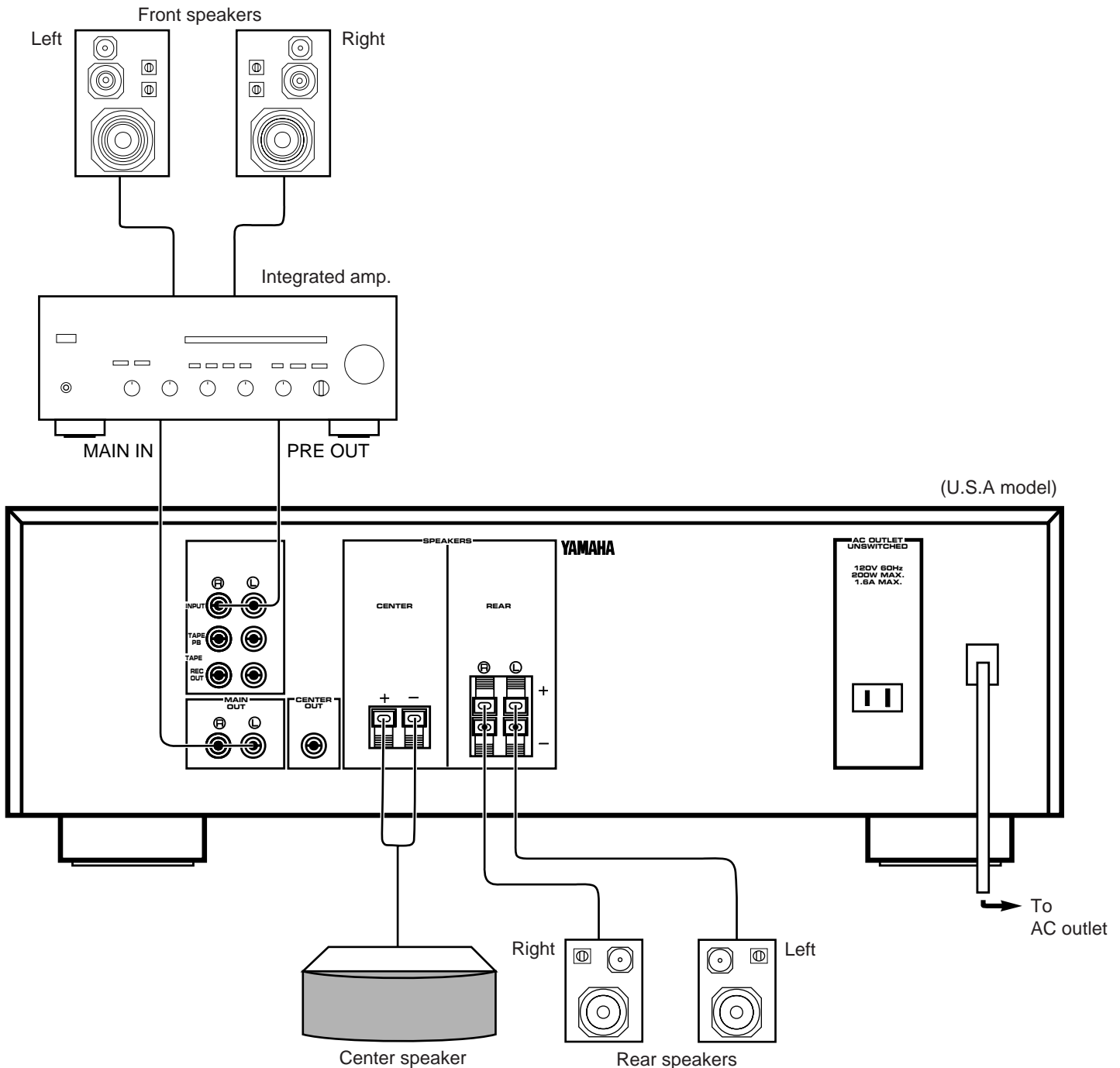

## **B** Connecting to an Integrated Amplifier or Stereo Receiver that does not have PRE OUT and MAIN IN terminals

If your amplifier or receiver has the REC OUT selector which is independent of the input selector, connect this unit to the amplifier or receiver tape REC OUT and auxiliary (AUX) input terminals. If not, connect this unit to the amplifier or receiver tape REC OUT and TAPE PB terminals.

If your system includes a tape deck which have been displaced by connecting this unit to the tape REC OUT terminals, reconnect your tape deck to this unit's TAPE REC OUT and TAPE REC OUT terminals.

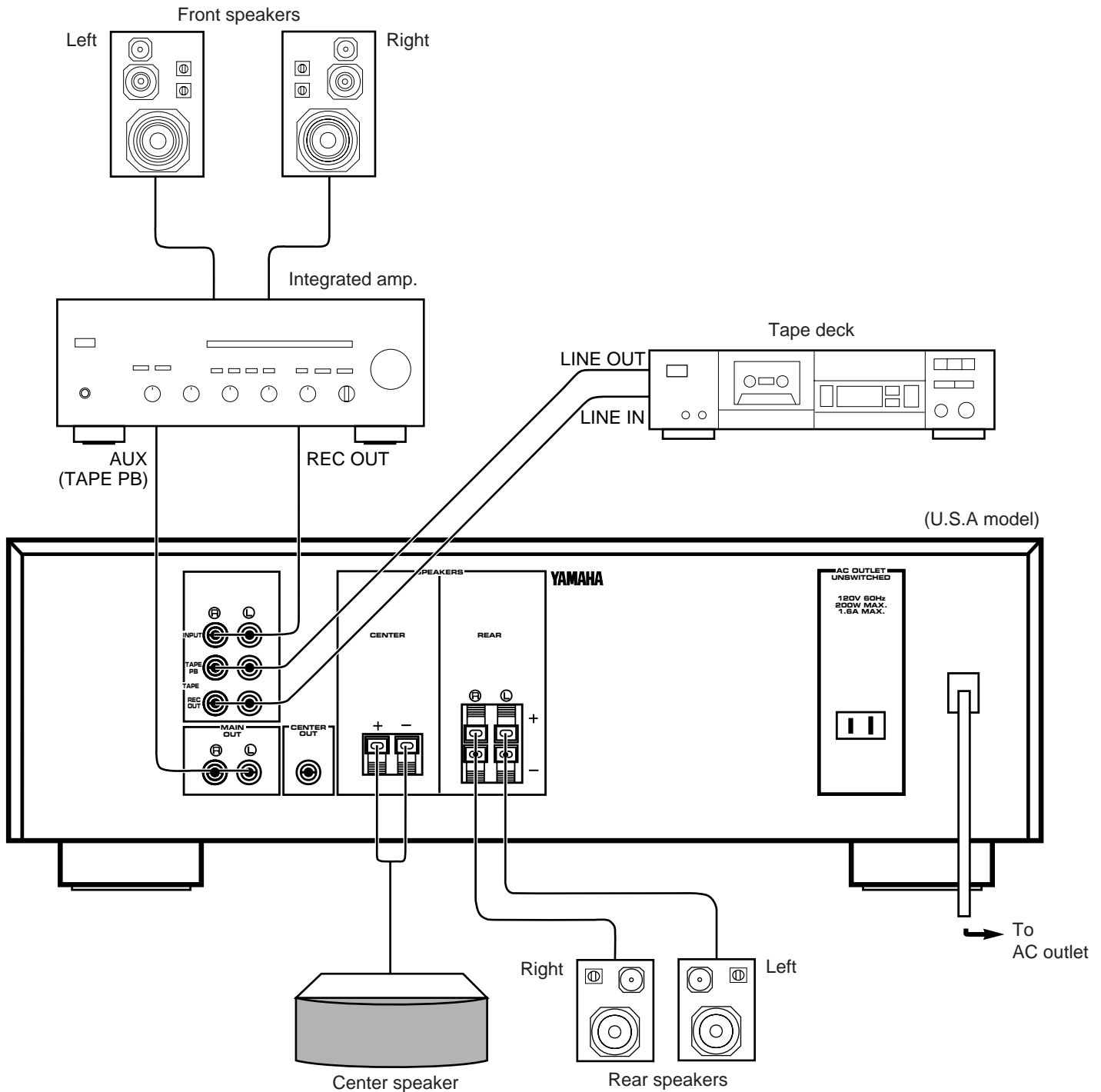

## C Connecting to a Control Amplifier and Power Amplifier

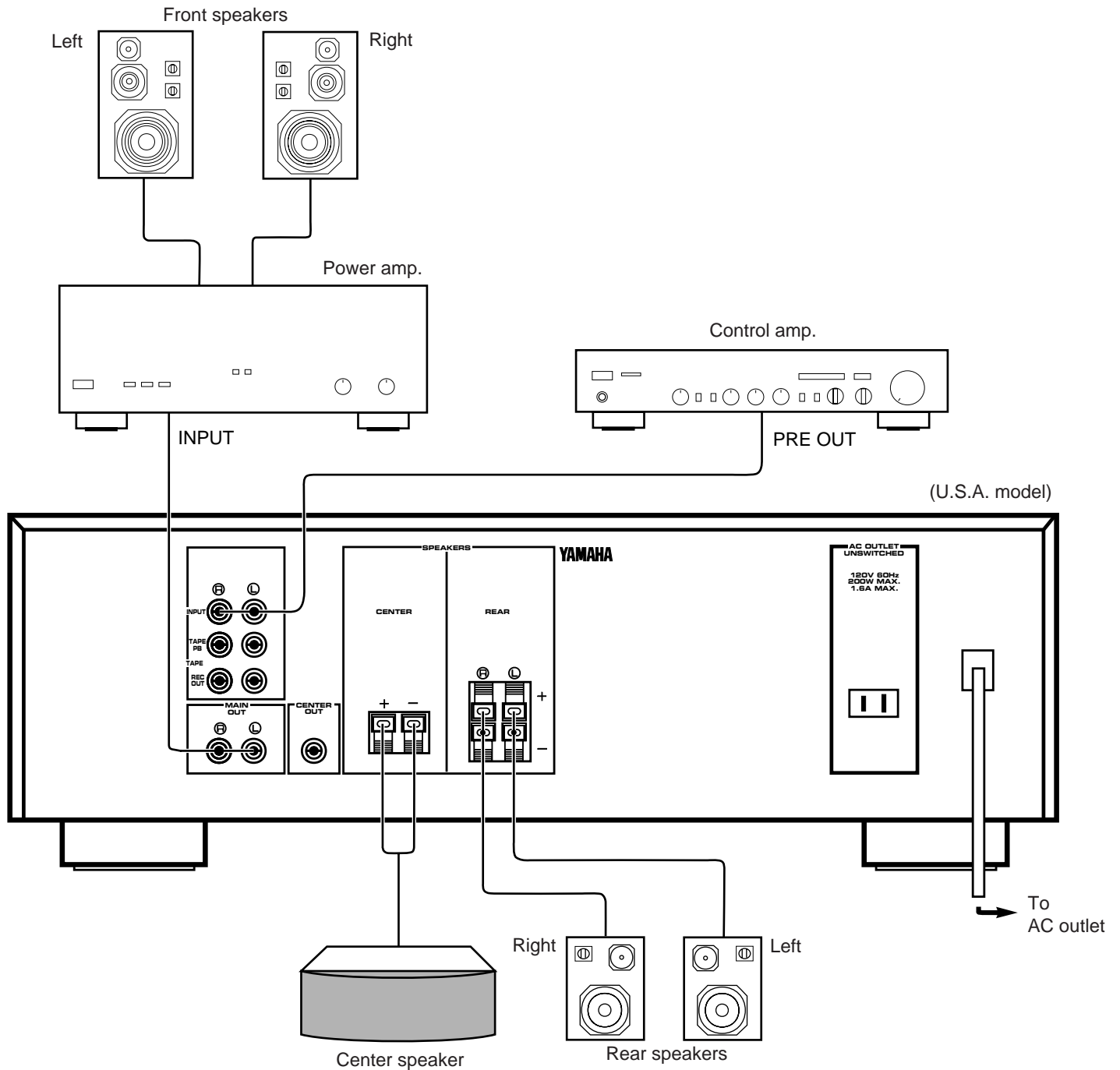



## CONNECTING SPEAKERS

---

Connect the **SPEAKERS** terminals to your speakers with wire of the proper gauge, cut to be as short as possible. If the connections are faulty, no sound will be heard from the speakers. Make sure that the polarity of the speaker wires is correct, that is, + and – markings are observed. If these wires are reversed, the sound will be unnatural and will lack bass.

**Do not let the bare speaker wires touch each other and do not let them touch the metal parts of this unit as this could damage this unit and/or speakers.**

\* Use speakers with the specified impedance shown on the rear of this unit.

### How to Connect:

Red: positive (+)  
Black: negative (–)

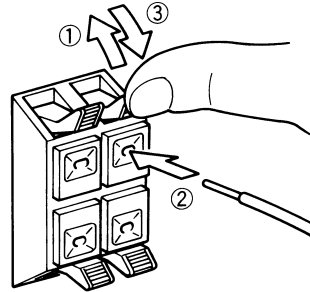

- ① Press and hold the tab.
- ② Insert the bare wire.  
[Remove approx. 5mm (1/4") insulation from the speaker wires.]
- ③ Release the tab and secure the wire.

## ABOUT THE ACCESSORY TERMINALS

---

### AC OUTLET (UNSWITCHED)

This unswitched AC outlet can be used for connection of the power cord from another audio component. Note that the power to that component is not affected by the ON or OFF setting of the **POWER** switch of this unit.

**Note:** The maximum power (total power consumption of components) that can be connected here is 200 watts.

### CENTER OUT terminal

This terminal is for center-channel line output. There is no connection to this terminal when you use the built-in amplifier. However, if you drive a center speaker with an external power amplifier, connect input terminal of the external amplifier to this terminal.

If you use the built-in amplifier and the external power amplifier at the same time, the sound will be output through both speakers.

# IDENTIFICATION OF CONTROLS

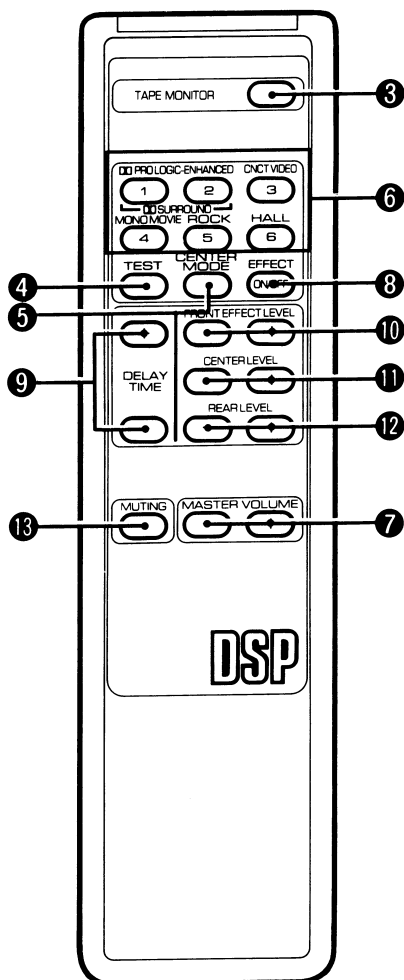
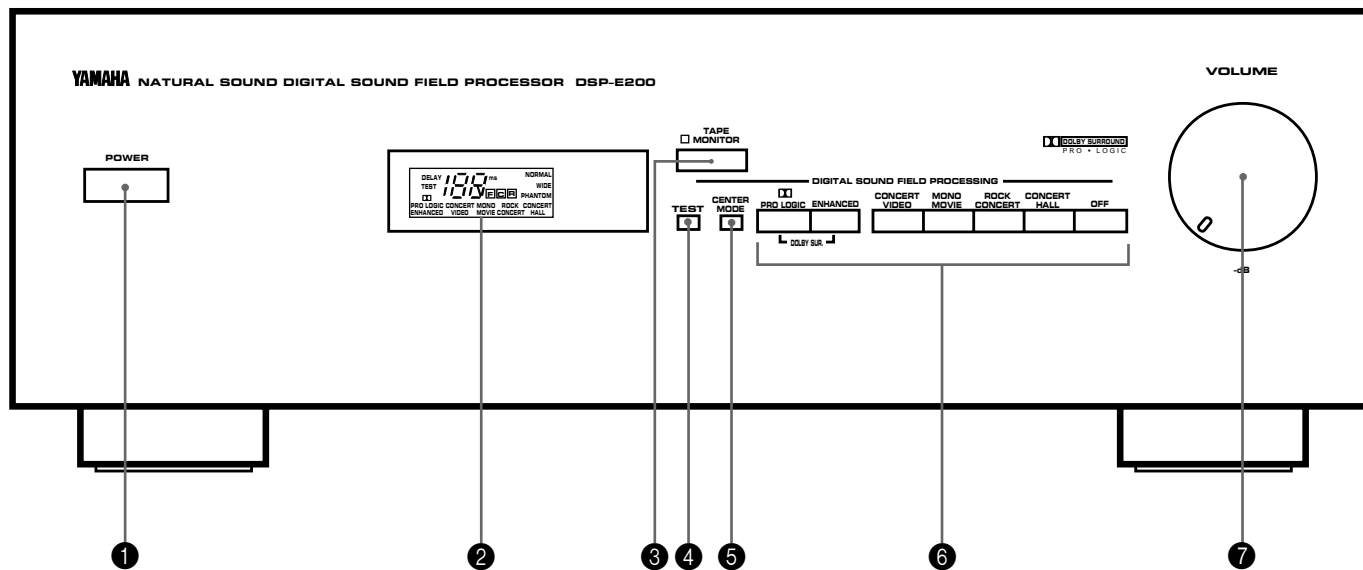

- 1 POWER**  
Turns the power on/off.
- 2 Display panel**  
Displays your selection on the DSP or other informations.
- 3 TAPE MONITOR**  
Used when you have connected the tape deck to this unit's TAPE terminals to select that tape as the source. (See page 14.)
- 4 TEST**  
Used for speaker balance adjustment. (See pages 11–12.)
- 5 CENTER MODE**  
Selects center speaker mode. (See page 11.)
- 6 DIGITAL SOUND FIELD PROCESSING programs**  
Selects a program from the digital sound field processor. (See pages 13–15.)
- 7 MASTER VOLUME**  
Turns the master volume level up/down.
- 8 EFFECT ON/OFF**  
Switches on/off the digital sound field processor. (See pages 13–15.)
- 9 DELAY TIME**  
Adjusts delay time. (See page 15.)
- 10 FRONT EFFECT LEVEL**  
Adjusts effect sound output level at front speakers. (See page 16.)
- 11 CENTER LEVEL**  
Adjusts center speaker sound output level. (See page 16.)
- 12 REAR LEVEL**  
Adjusts rear speaker sound output level. (See page 16.)
- 13 MUTING**  
When pressed, mutes the volume level. To resume original volume level, press this again. While muting, the indicator on the **VOLUME** control flashes on and off continuously.

# ADJUSTMENT BEFORE OPERATION

## SPEAKER BALANCE ADJUSTMENT

Using the built-in test tone generator, this procedure lets you adjust the sound output level balance between the front, center, and rear speakers. With this adjustment, the sound output level heard at the listening position will be the same from each speaker. This is important for the best performance of digital sound field processor.

**The adjustment of each speaker output level should be done at your listening position with the remote control transmitter. Otherwise, the result may not be satisfactory.**

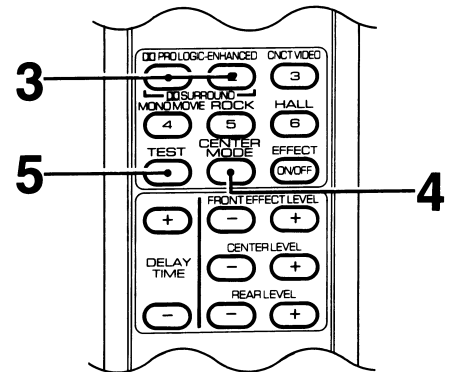
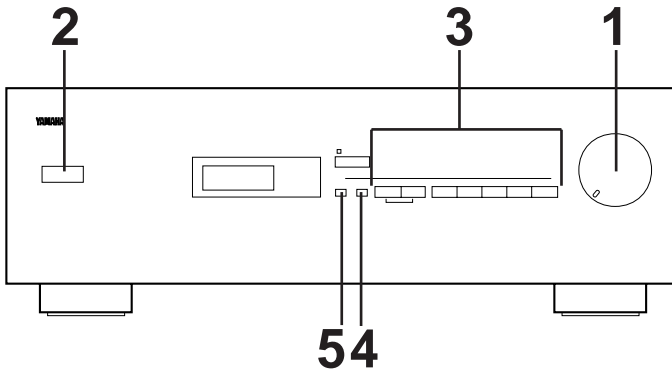

**1** **VOLUME**

Set to the "∞" position.

---

**2** Set on the **POWER** of this unit and the amplifier etc.

---

**3**

DIGITAL SOUND FIELD PROCESSING

<input type="checkbox"/> PRO LOGIC ENHANCED	CONCERT VIDEO	MONO MOVIE	ROCK CONCERT	CONCERT HALL	OFF
<input type="checkbox"/> DOLBY SUR					

**4** Select the center mode depending on your speaker configuration.  
(Refer to "**SPEAKER CONFIGURATION**" on page 5.)

NORMAL

↓

WIDE

↓

PHANTOM

CENTER MODE

On the feature of each mode, refer to the "Note" shown below.

---

**5**

Flashes on and off continuously.

**Note**  
In step 4, when you select the center mode, note the following.

For 5 speaker configuration)

**NORMAL:** Select this mode when you use the center speaker smaller sized than the front speakers. In this mode, the bass tone will be output from the front speakers.

**WIDE:** Select this mode when you use the center speaker approximately same sized as the front speakers.

For 4 speaker configuration)

**PHANTOM:** Select this mode when you do not use the center speaker. The center sound will be output from the left and the right front speakers.

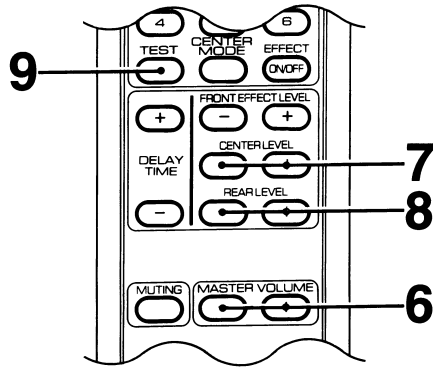

**6** Turn up the volume by using the remote control transmitter. You will hear a test tone (like pink noise) from the left front speaker, then the center speaker, then the right front speaker, then the rear speakers, for about two seconds each. The display illumination changes as shown below.

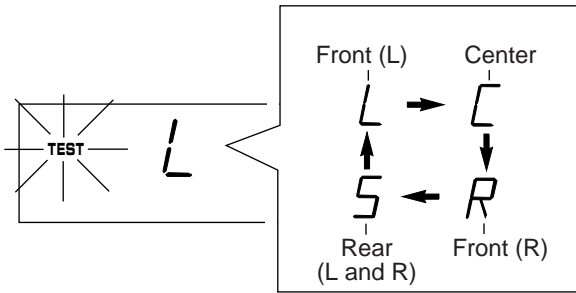

\* The test tone from the left rear speaker and the right rear speaker will be heard at the same time.

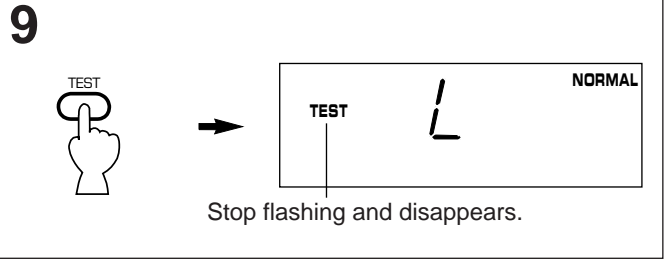

**Notes**

- Once you have completed these adjustments, use only this unit's **VOLUME** control to adjust listening volume. Do not change any other volume settings in this unit.
- If the connecting way of your components is **B** or **C** shown on pages 7–8, also adjust the volume control(s) on the integrated amplifier or power amplifier to achieve proper balance.
- In step 7, if the center mode is in the "PHANTOM", the sound output level of the center speaker can not be adjusted. Because in this mode, the center sound is automatically output from the left and right front speakers.

**7** Make the sound output level of the center speaker the same as that of the front speakers.

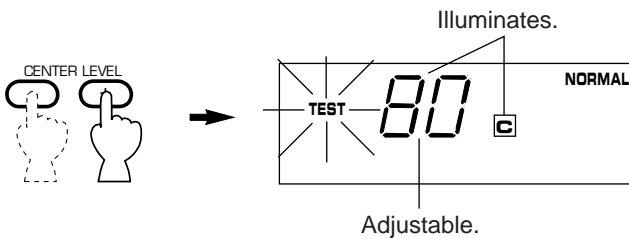

**8** Make the sound output level of the rear speakers the same as that of the front speakers.

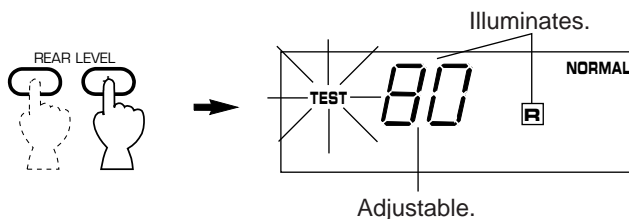

# USING DIGITAL SOUND FIELD PROCESSOR (DSP)

This unit incorporates a sophisticated, multi-program digital sound field processor, which allows you to expand and shape the audio sound field from both the audio and video sources, for a theater-like experience in the listening/viewing room. This digital sound field processor has 6 programs; 4 programs for digital sound field processing and 2 programs for the Dolby Pro Logic Surround sound system (**DOLBY PRO LOGIC** and **ENHANCED**). You can create excellent audio sound field by selecting the suitable program and adding desired adjustments. In addition, when the digital sound field program is in the **DOLBY PRO LOGIC** or **ENHANCED**, the built-in automatic input balance control functions. This presents you the best surround condition without adjusting it manually.

## DESCRIPTION OF EACH SOUND FIELD PROGRAM

PROGRAM	FEATURE
 <b>PRO LOGIC</b>	This program is effective on the play of the sources encoded with the Dolby Surround. The employment of the digital signal processing system improves crosstalk and transfers the sound source more smoothly and precisely, comparing with the conventional type. A stable movie sound field is recreated.
<b>ENHANCED</b>	This program is effective on the play of the sources encoded with the Dolby Surround. Enhancing the "Normal" Dolby Pro Logic, the DSP technology simulates the multi-surround speaker systems of the 35 mm film theater, so widening the surrounded-sound field with greater presence.
<b>CONCERT VIDEO</b>	This program is effective on music videos and excellent in depth and clarity for vocals. For opera, the orchestra and stage are ideally recreated, so letting you feel as if you were in an actual concert hall.
<b>MONO MOVIE</b>	This program is designed specifically to enhance mono source programs. Compared to a strictly mono setting, the sound image created in this mode is wider and slightly forward of the speaker pair, lending an immediacy to the overall sound. It is particularly effective when used with old mono movies, news broadcasts and dialogue.
<b>ROCK CONCERT</b>	This program will suit to rock music. A big, powerful sound is reproduced lively and dynamically.
<b>CONCERT HALL</b>	In this program, the center seems even more deeply behind the front speaker pair, creating an expansive, large hall ambience.

**OFF switch:** When any program is not used with the selected source, press this switch. The sound is output only from the front speakers.

### Description of Dolby Pro logic Surround

 **DOLBY PRO LOGIC SURROUND:** This unit employs the Dolby Pro Logic Surround system. This system is similar to professional Dolby Stereo decoders used in movie theaters. The Dolby Pro Logic Surround system, by employing a four-channel system, divides the input signals into four levels: the left and right main channels, the center channel (to characterize dialogue), and the rear surround-sound channels (to characterize sound effects, background noise and other ambient noise).

Dolby Surround is encoded on the sound track of commercially available video cassettes and video discs as well. When you play a source encoded with Dolby Surround on your home video system, the Dolby Pro Logic Surround mode on this unit decodes the signal and feeds the surround-sound effects. The Dolby Pro Logic Surround mode may not be always effective on video sources not encoded with Dolby Surround.

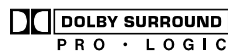

Manufactured under license from Dolby Laboratories Licensing Corporation. Additionally licensed under one or more of the following patents: U.S. numbers 3,632,886, 3,746,792, and 3,959,590; canadian numbers 1,004,603 and 1,037,877. "Dolby" and the double-D symbol are trademarks of Dolby Laboratories Licensing Corporation.

# TO PLAY SOURCE WITH THE DIGITAL SOUND FIELD PROCESSOR

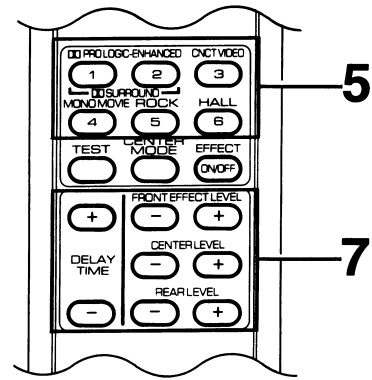
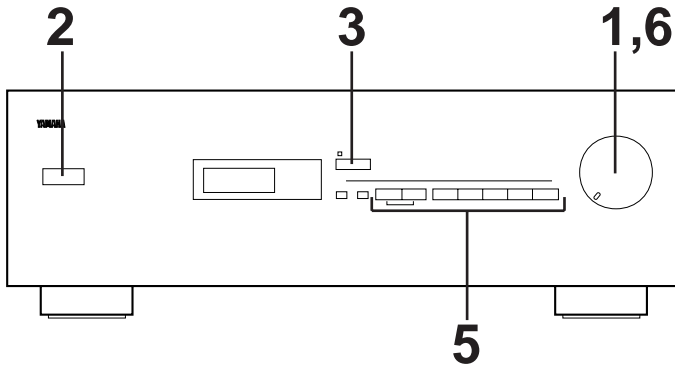

**1**

VOLUME

Set to the "∞" position.

---

**2**

POWER

---

**3** Select a source using the input selector on the integrated amplifier etc.

\* To select a tape deck connected to this unit's TAPE terminals, set the **TAPE MONITOR** switch to on. (Otherwise, set this switch to off.)

**Note**  
If this unit is connected to the TAPE REC OUT terminals of the integrated amplifier etc., the following operations should be done.

- If your amplifier has the REC OUT selector which is independent of the input selector;
  1. Set the input selector to the AUX position.
  2. Select the source to be input to this unit using the REC OUT selector.
- If your amplifier does not have the REC OUT selector which is independent of the input selector;
  1. Set the TAPE monitor switch on the amplifier to on.
  2. Select the source to be input to this unit using the input selector.

**4** Play the source.

---

**5** Select a desired program suitable for the source.

The corresponding indicator will illuminate.

---

**6**

VOLUME

Adjust to the desired output level.

---

**7** If desired, adjust the delay time and the output level of each speaker. (For details, refer to the corresponding descriptions on the next pages.)

### To obtain the best performance of this unit:

If the connecting way of your components is [A] or [C] shown on pages 6–8, set the volume control on the integrated amplifier or control amplifier to about the halfway position between the min. and max.

### Notes

- If you prefer to cancel the selected program, press the **OFF** switch. The sound will be the normal 2-channel stereo without surround sound effect.
- In the **CONCERT VIDEO, MONO MOVIE, ROCK CONCERT** and **CONCERT HALL**, no sound is heard from the center speaker.
- When the monaural sound source is played in the **DOLBY PRO LOGIC** or **ENHANCED**, no sound is heard from the front speakers and the rear speakers. Sound is heard only from the center speaker. However, if the center mode is in the **PHANTOM**, the front speakers output the sound of the center speaker.

- If the connected external amplifier has a built-in surround sound or ambience circuitry, be sure that the surround or ambience circuitry on that amplifier is off while you are using this unit's Dolby Pro Logic Surround decoding function.
- When this unit is in the Dolby Pro Logic Surround mode, if the main-source sound is considerably altered by overadjustment of the BASS or TREBLE controls on the integrated amplifier etc., the relationship with the center and rear channels may produce an unnatural effect.

## Adjustment of DELAY TIME

You can adjust the time difference between the beginning of the source sound and the beginning of the effect sound with the **DELAY TIME** keys.

The **DELAY TIME** keys are effective with all programs. By applying more or less delay, sound effects, background noise, and ambient noise coming at you from the rear speakers can be enhanced or subdued for extra effect.

- 1 **PRO LOGIC**: from 15 to 30 milliseconds (Preset value: 20 milliseconds)
- 2 **ENHANCED**: from 15 to 30 milliseconds (Preset value: 20 milliseconds)
- 3 **CONCERT VIDEO**: from 1 to 100 milliseconds (Preset value: 25 milliseconds)
- 4 **MONO MOVIE**: from 1 to 100 milliseconds (Preset value: 25 milliseconds)
- 5 **ROCK CONCERT**: from 1 to 100 milliseconds (Preset value: 15 milliseconds)
- 6 **CONCERT HALL**: from 1 to 100 milliseconds (Preset value: 30 milliseconds)

By continuously pressing “+” or “-” of the **DELAY TIME** keys, the value changes continuously. However, the value stops changing momentarily at the preset point.

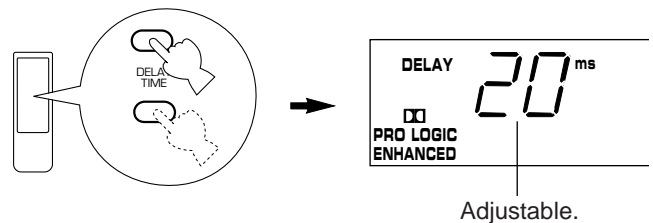

### Note

Adding too much delay will cause an unnatural effect with some sources. Experiment with the **DELAY TIME** keys to create an effect that you find most suitable.

## Adjustment of the FRONT EFFECT LEVEL

If desired, you can adjust the effect sound output level of the front speakers with these keys. The output level is preset to be 80. However, you can adjust the level between 1 and 100.

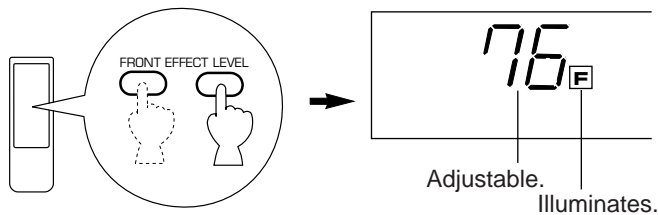

- If the digital sound field program is in the **DOLBY PRO LOGIC**, the **FRONT EFFECT LEVEL** keys do not function.
- Once the output level is adjusted, the level value will be common among all the digital sound field programs except the **DOLBY PRO LOGIC**.
- If any digital sound field program is not used, the **FRONT EFFECT LEVEL** keys do not function.

## Adjustment of the CENTER LEVEL

If desired, you can adjust the sound output level of the center speaker with these keys even if the output level is already set in "SPEAKER BALANCE ADJUSTMENT" on page 12.

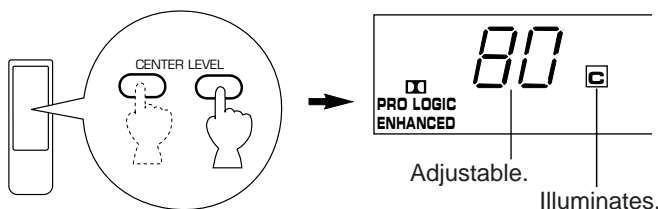

- By continuously pressing "+" or "-" of the **CENTER LEVEL** keys, the level value changes continuously. However, the value stops changing momentarily at the point which was once set in the **TEST** mode.
- If the digital sound field program is in the **CONCERT VIDEO, MONO MOVIE, ROCK CONCERT** or **CONCERT HALL**, the **CENTER LEVEL** keys can not function.
- Once the output level is adjusted, the level value will be common among the **DOLBY PRO LOGIC** and **ENHANCED**.
- If any digital sound field program is not used, the **CENTER LEVEL** keys do not function.

## Adjustment of the REAR LEVEL

If desired, you can adjust the sound output level of the rear speakers with these keys even if the output level is already set in "SPEAKER BALANCE ADJUSTMENT" on page 12.

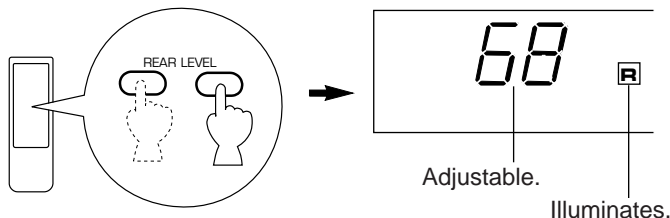

- By continuously pressing "+" or "-" of the **REAR LEVEL** keys, the level value changes continuously. However, the value stops changing momentarily at the point which was once set in the **TEST** mode.
- Once the output level is adjusted, the level value will be common among all the digital sound field programs.
- If any digital sound field program is not used, the **REAR LEVEL** keys do not function.

### Note

The values of the **DELAY TIME**, the **FRONT EFFECT LEVEL**, **CENTER LEVEL**, and **REAR LEVEL** you set the last time will remain memorized even when the power of this unit is off. However, if the power plug cord is disconnected for more than two weeks, these values will revert to factory-preset levels.



# NOTES ABOUT THE REMOTE CONTROL TRANSMITTER

## Battery installation

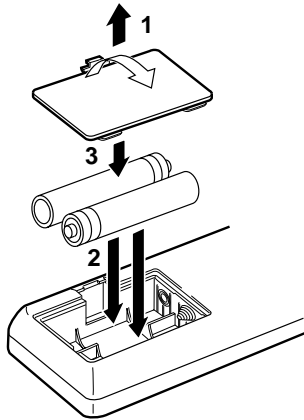

## Battery replacement

If you find that the remote control transmitter must be used closer to the main unit, the batteries are weak. Replace both batteries with new ones.

### Notes

- Use only AA, R6, UM-3 batteries for replacement.
- Be sure the polarities are correct. (See the illustration inside the battery compartment.)
- Remove the batteries if the remote control transmitter will not be used for an extended period of time.
- If batteries leak, dispose of them immediately. Avoid touching the leaked material or letting it come in contact with clothing, etc. Clean the battery compartment thoroughly before installing new batteries.

## Remote-control transmitter operation range

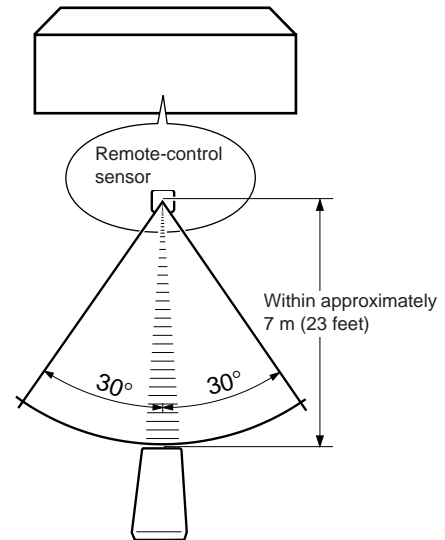

### Notes

- There should be no large obstacles between the remote control transmitter and the main unit.
- If the remote control sensor is directly illuminated by strong lighting (especially an inverter type of fluorescent lamp etc.), it might cause the remote control transmitter not to work correctly. In this case, reposition the main unit to avoid direct lighting.

# SPECIFICATIONS

Minimum RMS Output Power per Channel Center (8 ohms, 20 Hz – 20 kHz, 0.08% THD) .....25W	Rear L, R (8 ohms, 1 kHz, 0.3% THD) .....25W+25W
Input Sensitivity/Impedance INPUT.....150 mV/47 k-ohms	
Output Level/Impedance MAIN OUT/CENTER OUT.....1V/1 k-ohms	
Frequency Response (20 Hz to 20 kHz) INPUT to MAIN OUT .....0±0.5 dB	
Total Harmonic Distortion (20 Hz to 20 kHz) INPUT to MAIN OUT (1 V) .....0.01%	
Signal-to-Noise Ratio (IHF-A Network) MAIN OUT (Input Shorted).....95 dB	
Residual Noise (IHF-A Network) MAIN OUT.....5 µV	
Channel Separation (Input 5.1 k-ohms Shorted 1 kHz/10 kHz).....65 dB/50 dB	

Power Supply	[U.S.A. and Canada models].....AC 120 V, 60 Hz
	[Australia and U.K. models].....AC 240 V, 50 Hz
	[Europe model].....AC 230 V, 50 Hz
	[General model].....AC 110/120/220/240V, 50/60 Hz
Power Consumption	.....90W
AC Outlet	1 UNSWITCHED OUTLET.....200W max. total
Dimensions (W x H x D)	.....435 x 151.3 x 296.7 mm (17-1/8" x 5-15/16" x 11-11/16")
Weight	.....7.7 kg (16 lbs. 15 oz.)
Accessories	.....Remote control transmitter Batteries Audio connection cord x 2

Specifications subject to change without notice.

# TROUBLESHOOTING

If the unit fails to operate normally, check the following points to determine whether the fault can be corrected by the simple measures suggested. If it cannot be corrected, or if the fault is not listed in the SYMPTOM column, disconnect the power cord and contact your authorized YAMAHA dealer or service center for help.

SYMPTOM	CAUSE	REMEDY
<b>The unit fails to turn on when the POWER switch is pressed.</b>	Power cord is not plugged in or is not completely inserted.	Firmly plug in the power cord.
<b>No sound.</b>	Incorrect output cord connections.	Connect the cords properly. If the problem persists, the cords may be defective.
	The MUTING switch is ON.	First, turn the volume control to the full left. Then, turn the MUTING switch off with the remote control transmitter and adjust the volume.
<b>The sound suddenly goes off.</b>	The protection circuit has activated because of short circuit etc.	Turning the unit off and then on will reset the protection circuit.
<b>Only one side speaker outputs the sound.</b>	Incorrect cord connections.	Connect the cords properly. If the problem persists, the cords may be defective.
<b>Sound "hums".</b>	Incorrect cord connections.	Firmly connect the audio plugs. If the problem persists, the cords may be defective.
<b>No sound from the rear speakers.</b>	The rear effect sound output level is set to 0.	Turn up the sound output level with the REAR LEVEL keys.
	The monaural sound source is played in the DOLBY PRO LOGIC or ENHANCED.	Select another program suitable for the monaural sound source.
<b>No sound from the center speaker.</b>	The center sound output level is set to 0.	Turn up the sound output level with the CENTER LEVEL keys.
	The center mode is in the PHANTOM.	Select the NORMAL or WIDE.
	Incorrect sound field program selection.	Select an appropriate program.
	No sound field program is selected.	
<b>The remote control transmitter does not work.</b>	Direct sunlight or lighting (of an inverter type of fluorescent lamp etc.) is striking the remote control sensor of the main unit.	Change position of the main unit.
<b>The distance or range within which the remote control transmitter can be used decreases.</b>	The batteries of this remote control transmitter are too weak.	Replace the batteries with new ones.
<b>The sound is degraded when monitoring is performed by using the headphones connected to the compact disc player or cassette deck which are connected with this unit.</b>	Power cord of this unit is not plugged.	Plug in the power cord.

# YAMAHA

---

YAMAHA ELECTRONICS CORPORATION, USA 6660 ORANGETHORPE AVE., BUENA PARK, CALIF. 90620, U.S.A.  
YAMAHA CANADA MUSIC LTD. 135 MILNER AVE., SCARBOROUGH, ONTARIO M1S 3R1, CANADA  
YAMAHA ELECTRONIK EUROPA G.m.b.H. SIEMENSSTR. 22-34, D-25462 RELLINGEN BEI HAMBURG, F.R. OF GERMANY  
YAMAHA ELECTRONIQUE FRANCE S.A. RUE AMBROISE CROIZAT BP70 CROISSY-BEAUBOURG 77312 MARNE-LA-VALLEE CEDEX02, FRANCE  
YAMAHA ELECTRONICS (UK) LTD. YAMAHA HOUSE, 200 RICKMANSWORTH ROAD WATFORD, HERTS WD1 7JS, ENGLAND  
YAMAHA SCANDINAVIA A.B. J A WETTERGRENS GATA 1, BOX 30053, 400 43 VÄSTRA FRÖLUNDA, SWEDEN  
YAMAHA MUSIC AUSTRALIA PTY, LTD. 17-33 MARKET ST., SOUTH MELBOURNE, 3205 VIC., AUSTRALIA

YAMAHA CORPORATION