



DIGITAL MIXING SYSTEM

RIVAGE
PM7

Block Diagram

Block Diagram

System Overview

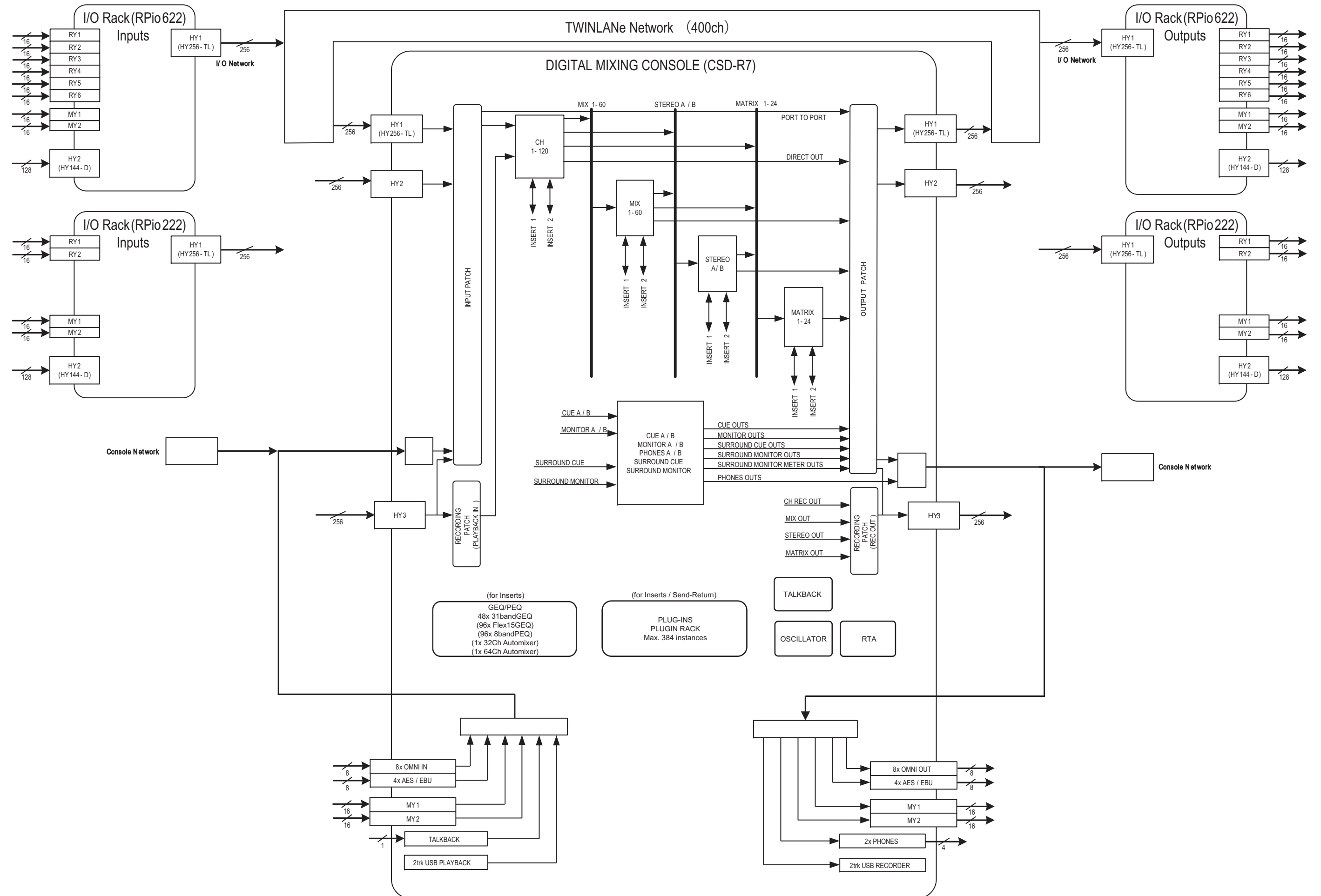

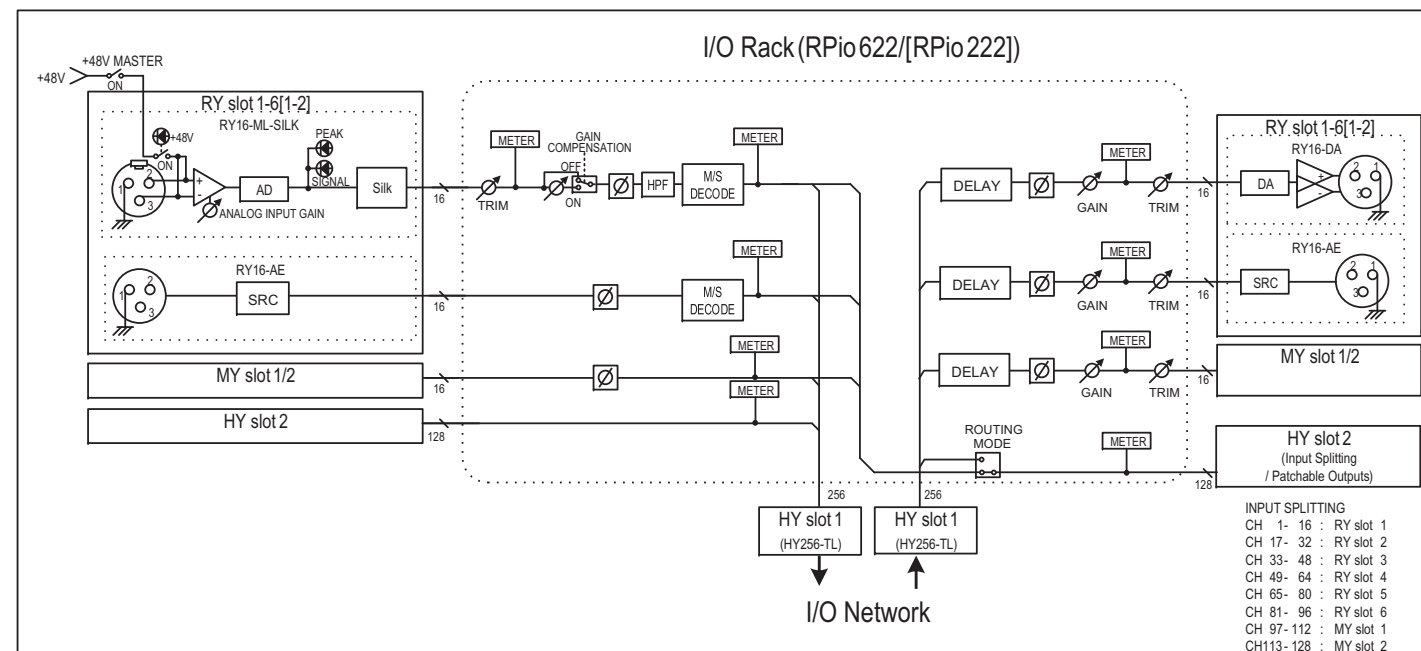
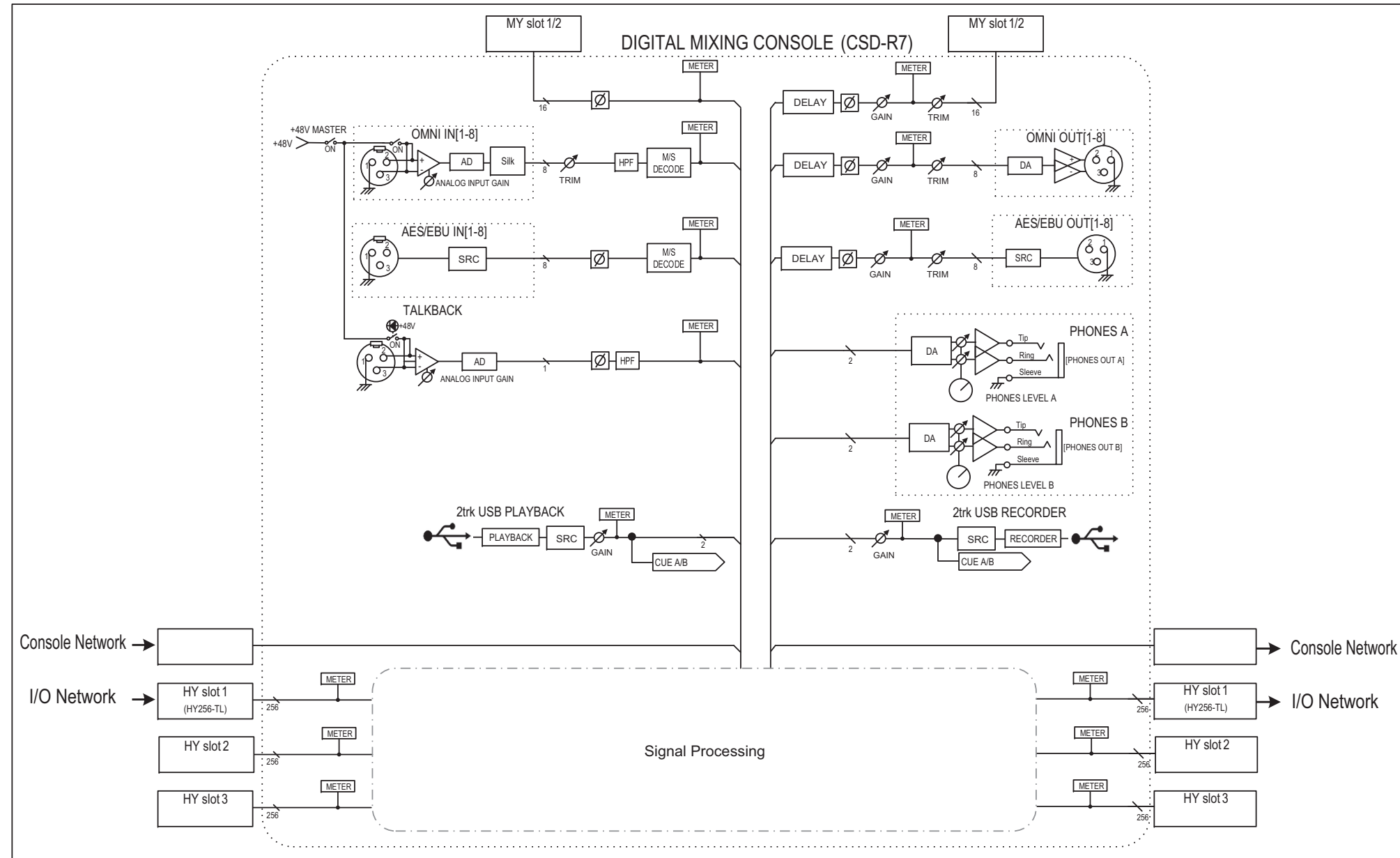

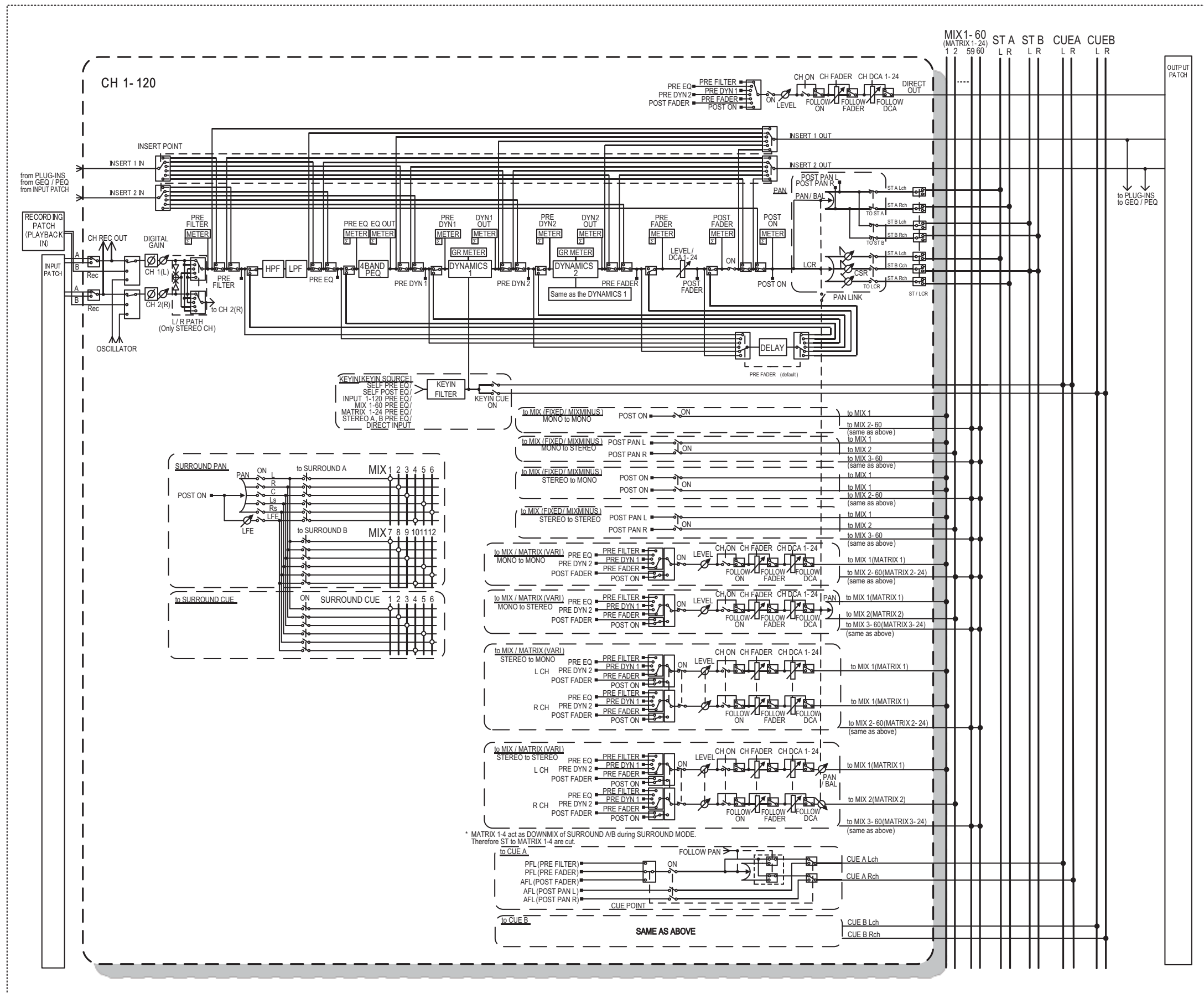

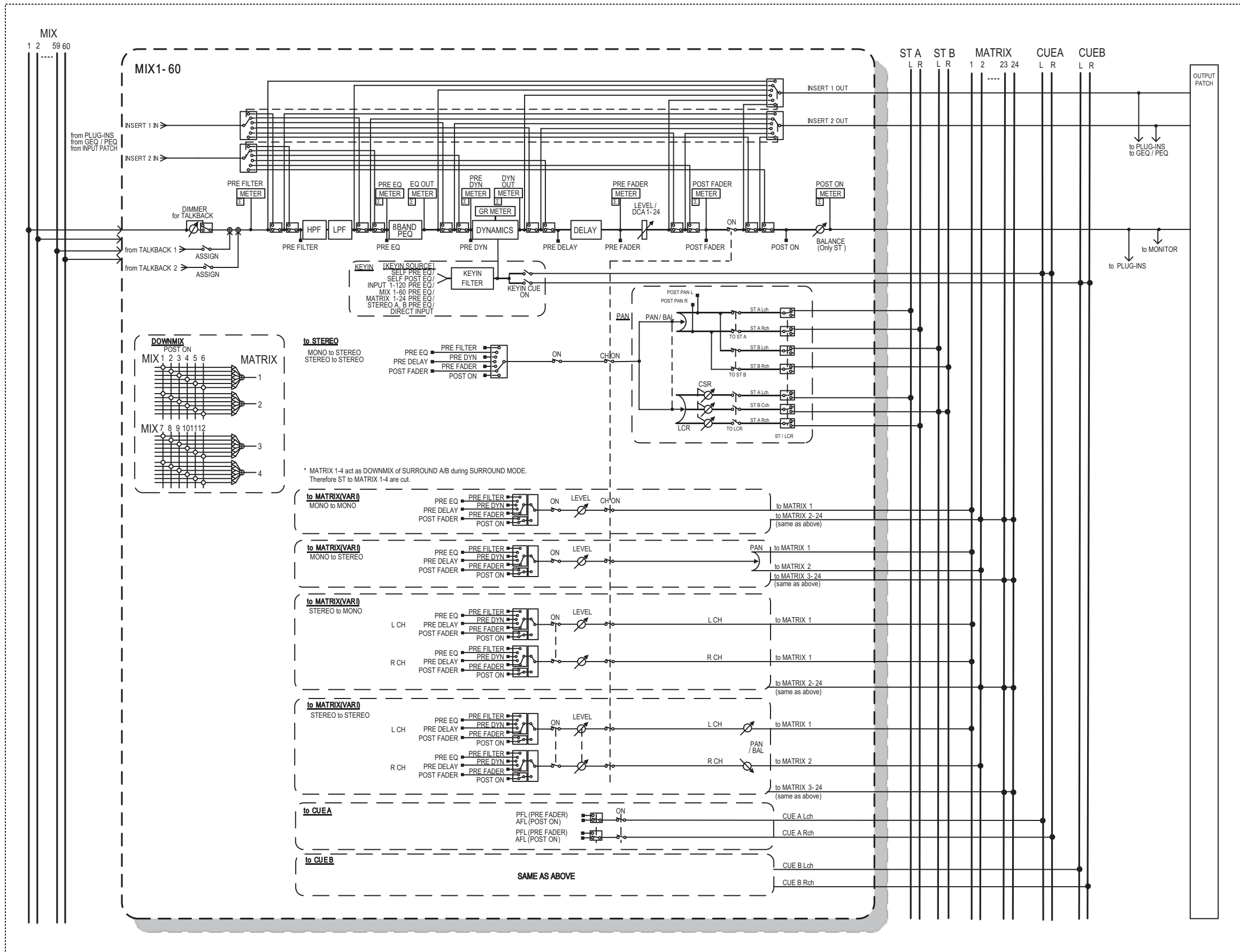

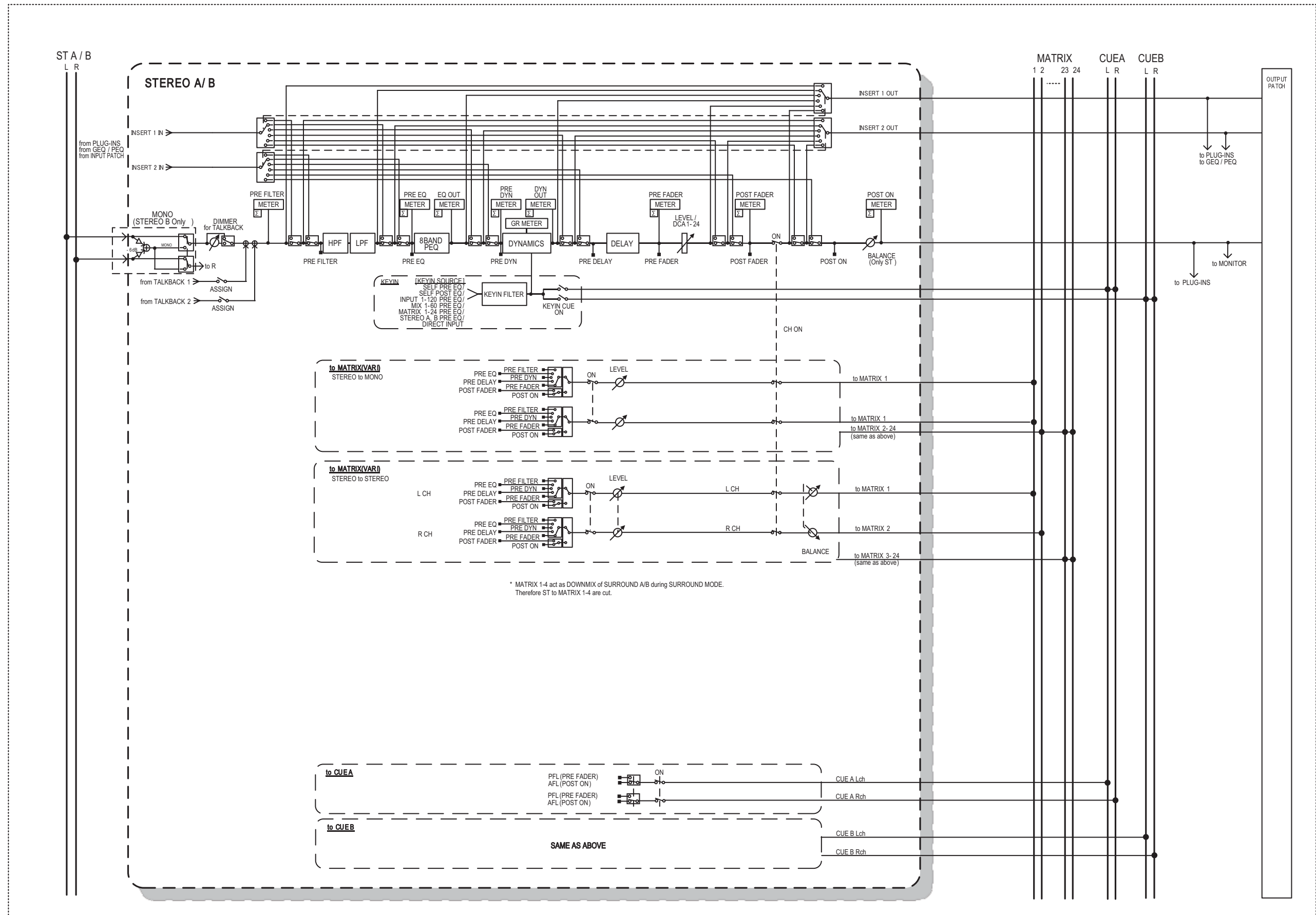

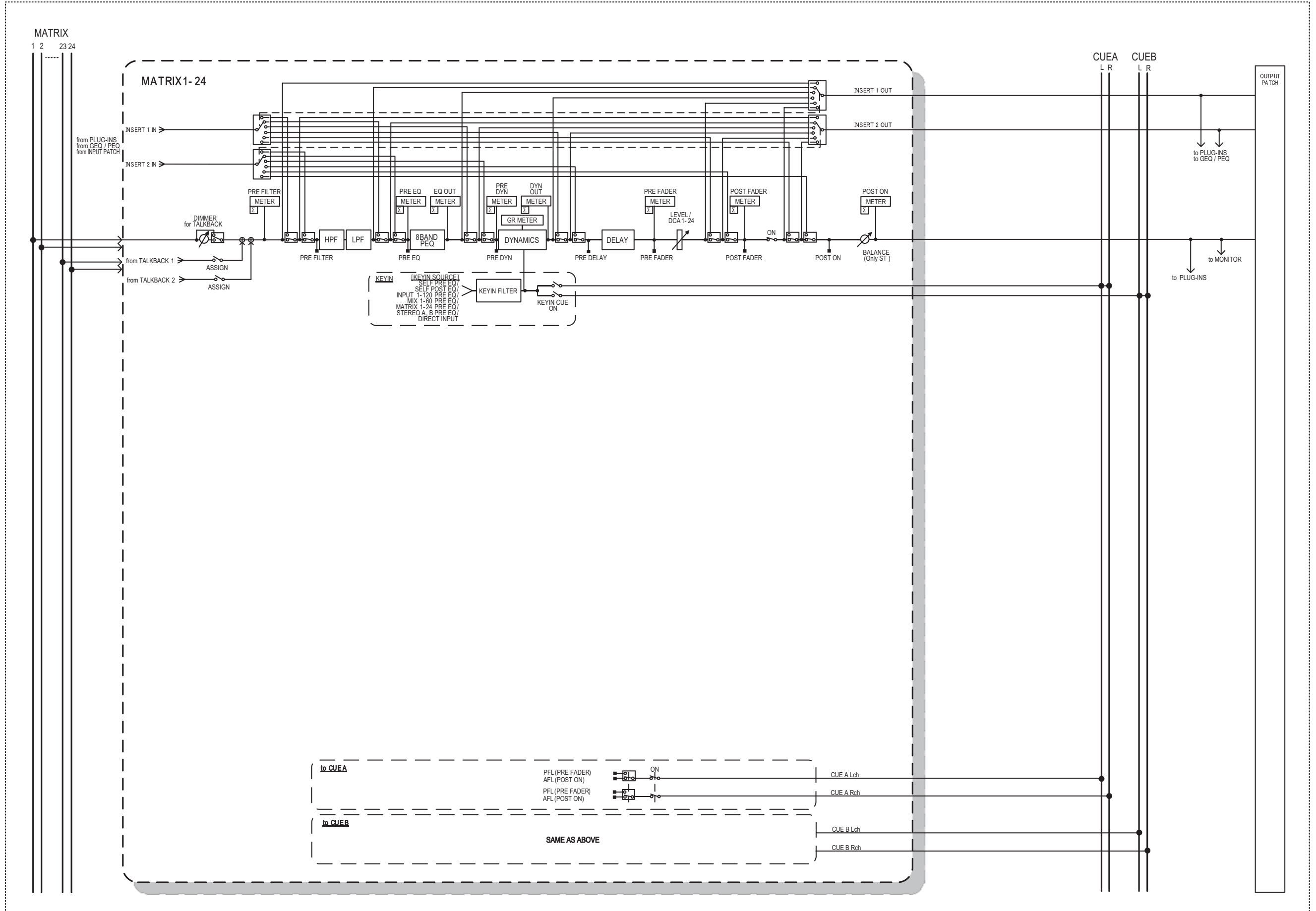

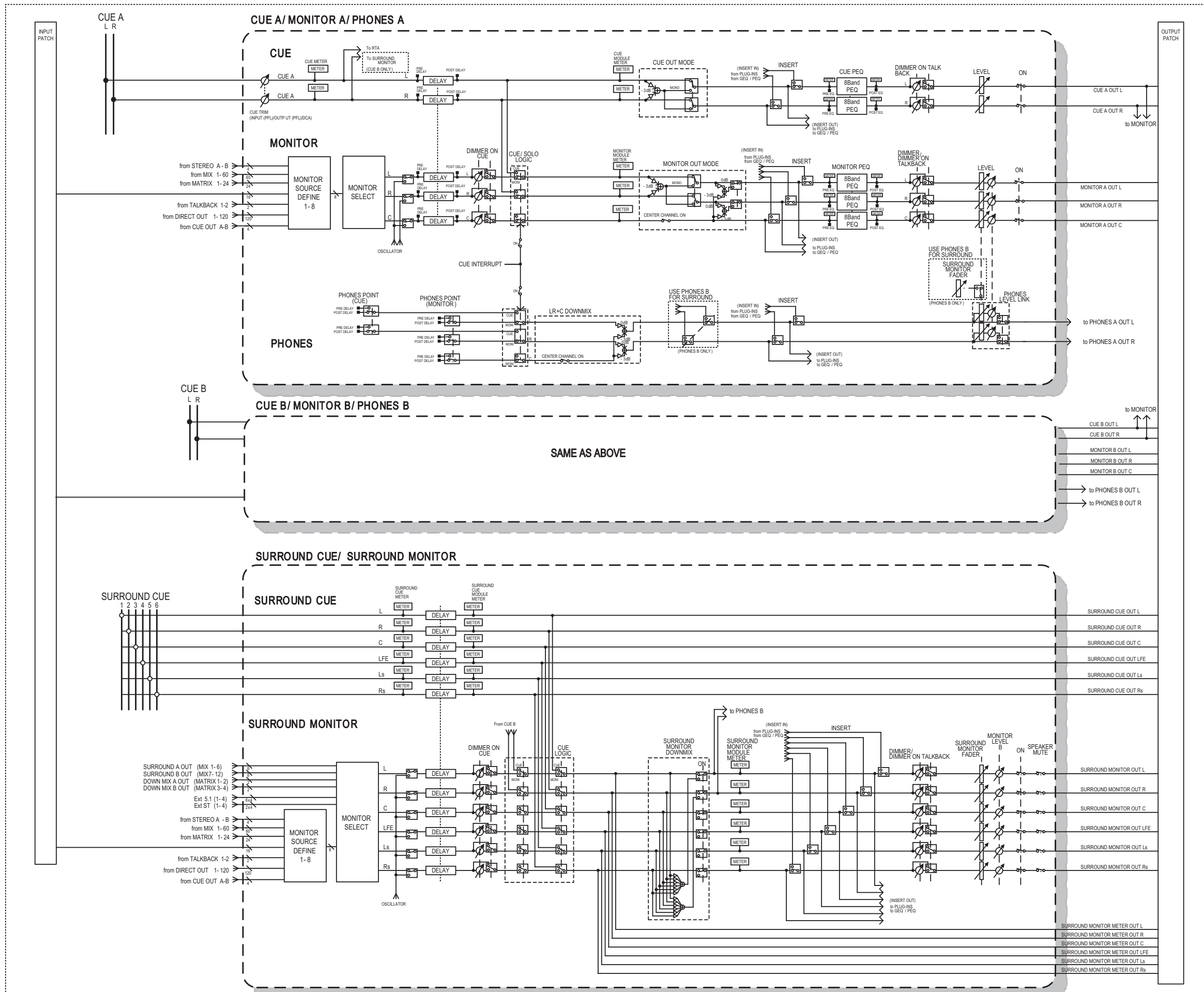

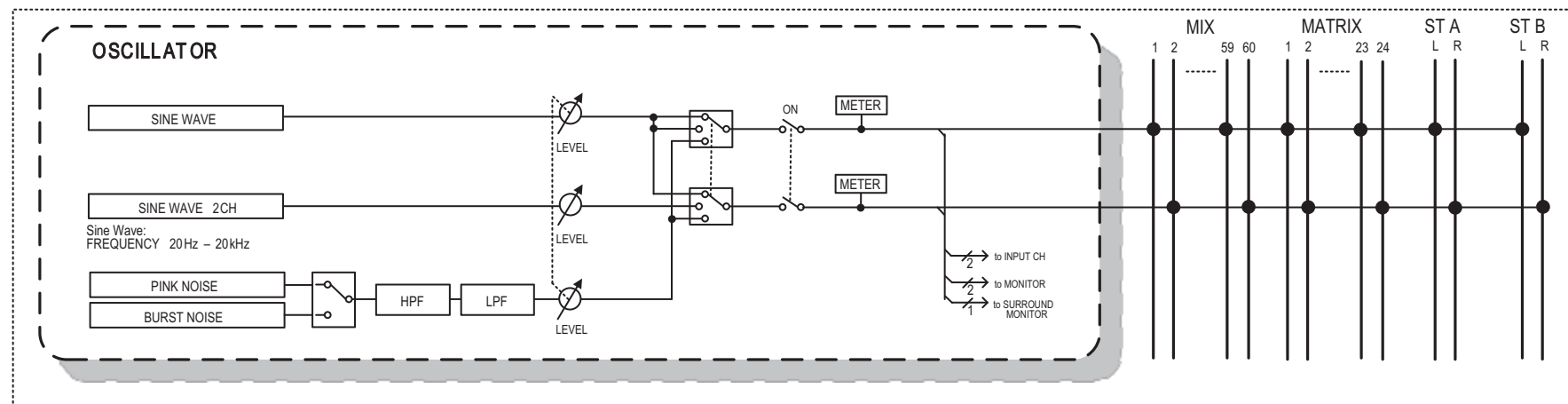
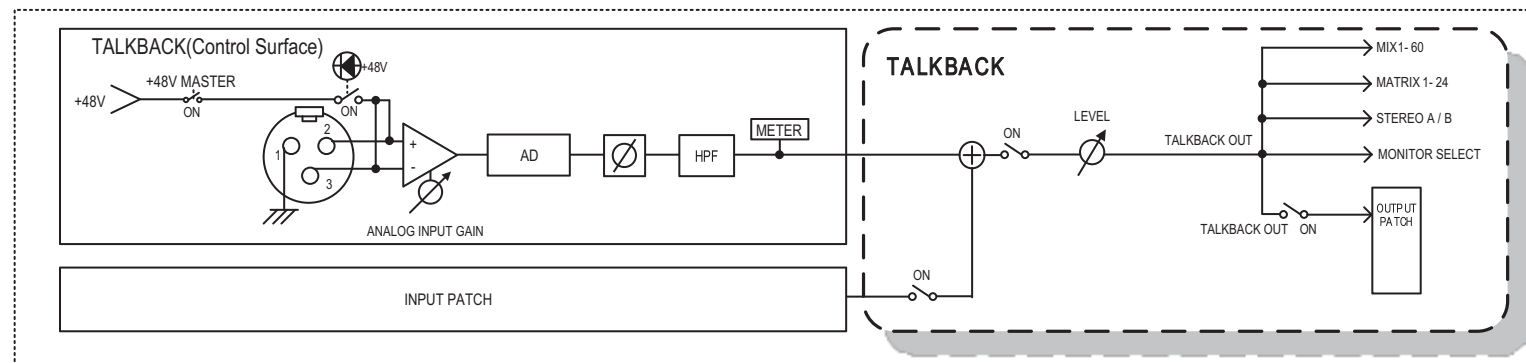
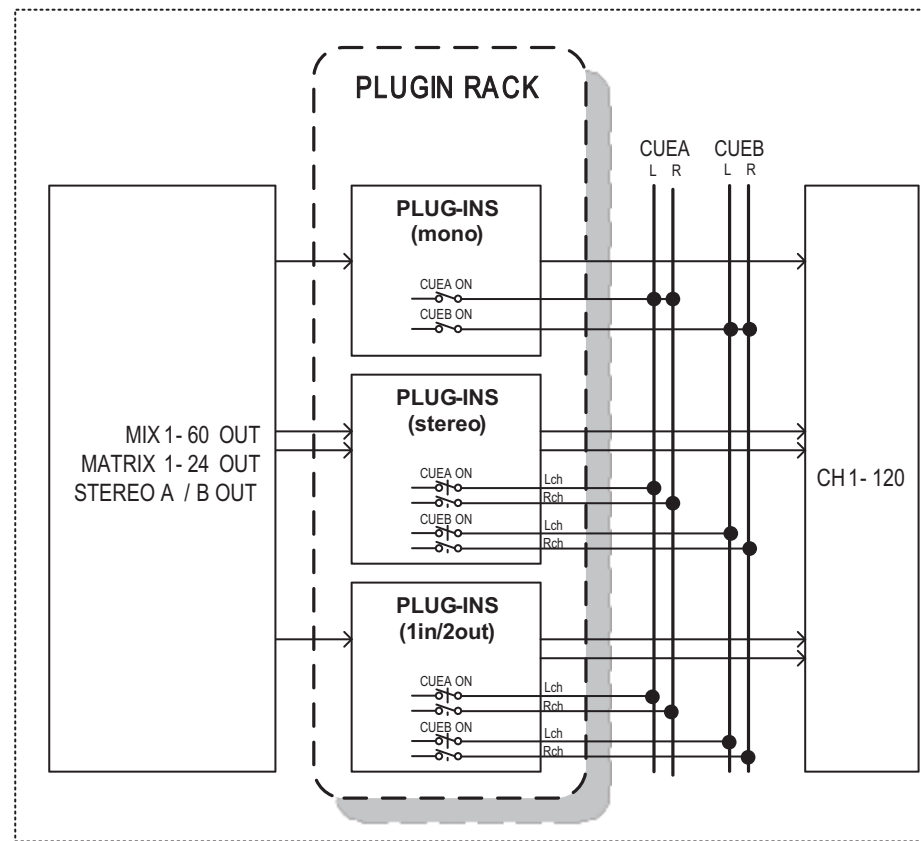

Level Diagram

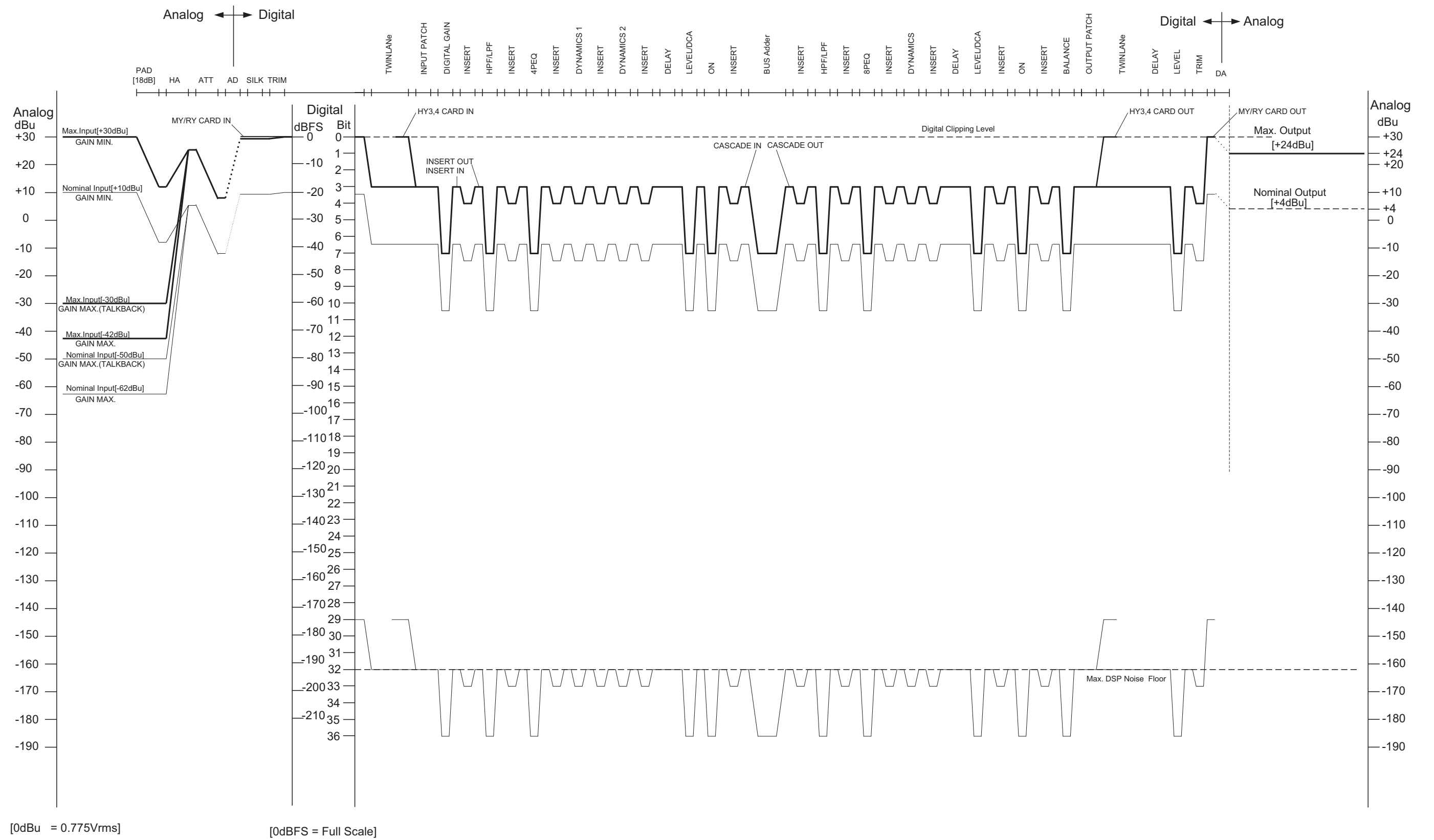

Yamaha Pro Audio global website
<https://www.yamaha.com/proaudio/>
Yamaha Downloads
<https://download.yamaha.com/>

Manual Development Group
© 2018 Yamaha Corporation

Published 09/2018 IPTO-C0

VCG5790