

MCR-040/140

(CRX-040/140 + NS-BP80)

MICRO COMPONENT SYSTEM



OWNER'S MANUAL

Caution: Read this before operating your unit.

- 1 To assure the finest performance, please read this manual carefully. Keep it in a safe place for future reference.
- 2 Install this sound system in a well ventilated, cool, dry, clean place - away from direct sunlight, heat sources, vibration, dust, moisture, and/or cold. For proper ventilation, allow the following minimum clearances around CRX-040/140.
Top: 10 cm (4 in)
Rear: 10 cm (4 in)
Sides: 10 cm (4 in)
- 3 Locate this unit away from other electrical appliances, motors, or transformers to avoid humming sounds.
- 4 Do not expose this unit to sudden temperature changes from cold to hot, and do not locate this unit in an environment with high humidity (i.e. a room with a humidifier) to prevent condensation inside this unit, which may cause an electrical shock, fire, damage to this unit, and/or personal injury.
- 5 Avoid installing this unit where foreign object may fall onto this unit and/or this unit may be exposed to liquid dripping or splashing. On the top of this unit, do not place:
 - Other components, as they may cause damage and/or discoloration on the surface of this unit.
 - Burning objects (i.e. candles), as they may cause fire, damage to this unit, and/or personal injury.
 - Containers with liquid in them, as they may fall and liquid may cause electrical shock to the user and/or damage to this unit.
- 6 Do not cover this unit with a newspaper, tablecloth, curtain, etc. in order not to obstruct heat radiation. If the temperature inside this unit rises, it may cause fire, damage to this unit, and/or personal injury.
- 7 Do not plug in this unit to a wall outlet until all connections are complete.
- 8 Do not operate this unit upside-down. It may overheat, possibly causing damage.
- 9 Do not use force on switches, knobs and/or cords.
- 10 When disconnecting the power cable from the wall outlet, grasp the plug; do not pull the cable.
- 11 Do not clean this unit with chemical solvents; this might damage the finish. Use a clean, dry cloth.
- 12 Only voltage specified on this unit must be used. Using this unit with a higher voltage than specified is dangerous and may cause fire, damage to this unit, and/or personal injury. Yamaha will not be held responsible for any damage resulting from use of this unit with a voltage other than specified.
- 13 To prevent damage by lightning, keep the power cable and outdoor antennas disconnected from a wall outlet or this unit during a lightning storm.
- 14 Do not attempt to modify or fix this unit. Contact qualified Yamaha service personnel when any service is needed. The cabinet should never be opened for any reasons.
- 15 When not planning to use this unit for long periods of time (i.e. vacation), disconnect the AC power plug from the wall outlet.
- 16 Be sure to read the “TROUBLESHOOTING” section on common operating errors before concluding that this unit is faulty.
- 17 Before moving this unit, press \odot to set this unit to the standby mode, and disconnect the AC power plug from the wall outlet.
- 18 Condensation will form when the surrounding temperature changes suddenly. Disconnect the power cable from the outlet, then leave this unit alone.
- 19 When using this unit for a long time, this unit may become warm. Turn the power off, then leave this unit alone for cooling.
- 20 Install this unit near the AC outlet and where the AC power plug can be reached easily.
- 21 The batteries shall not be exposed to excessive heat such as sunshine, fire or the like. When you dispose of batteries, follow your regional regulations.
- 22 Excessive sound pressure from earphones and headphones can cause hearing loss.

This unit is not disconnected from the AC power source as long as it is connected to the wall outlet, even if this unit itself is turned off by \odot . This state is called the standby mode. In this state, this unit is designed to consume a very small quantity of power.

WARNING

TO REDUCE THE RISK OF FIRE OR ELECTRIC SHOCK, DO NOT EXPOSE THIS UNIT TO RAIN OR MOISTURE.

LASER SAFETY

This unit employs a laser. Due to possible eye injury, only a qualified service person should remove the cover or attempt to service this device.

DANGER

This unit emits visible laser radiation when open. Avoid direct eye exposure to beam. When this unit is plugged into the wall outlet, do not place your eyes close to the opening of the disc tray and other openings to look into inside.

The laser component in this product is capable of emitting radiation exceeding the limit for Class 1.

CAUTION

Danger of explosion if battery is incorrectly replaced. Replace only with the same or equivalent type.

Radio waves may affect electro-medical devices. Do not use MCR-140 near medical devices or inside medical facilities.

Do not use MCR-140 within 22 cm (9 in) of persons with a heart pacemaker implant or defibrillator implant.

We, the manufacturer Yamaha hereby declare that the MCR-140 is in compliance with the essential requirements and other relevant provisions of Directive 1999/5/EC.

CONTENTS

PREPARATION

PARTS	2
PLAYABLE DISCS AND FILE FORMAT	3
CONNECTION	4
Basic connection.....	4
Wireless connection MCR-140	5
Other connection.....	5
REMOTE CONTROL	6
FRONT PANEL DISPLAY	6

OPERATION

FRONT PANEL AND BASIC OPERATION	7
LISTENING TO MUSIC	8
Playback operation.....	8
Other operation	9
LISTENING TO DAB STATIONS	10
Preparing the DAB tuning	10
Tuning DAB stations	10
Presetting DAB stations.....	10
Selecting preset DAB stations (Preset tuning).....	10
DAB station information	11
DAB frequency information.....	11
LISTENING TO FM STATIONS	12
Tuning to FM stations.....	12
Presetting FM stations	12
Selecting preset FM stations (Preset tuning)	12
Displaying Radio Data System information (U.K. model only)	12
USING USEFUL FUNCTIONS	13
Using setup menu	13
Using DAB option menu	15
Using timer and sleep timer.....	16

ADDITIONAL INFORMATION



TROUBLESHOOTING	17
General.....	17
DAB reception.....	18
FM reception.....	18
iPod™.....	19
USB	21
Disc playback	22
Remote control	22
HANDLING COMPACT DISCS	23
SPECIFICATIONS	23

PREPARATION

OPERATION

ADDITIONAL
INFORMATION

■ About this manual

- This manual describes how to operate this unit using a remote control except when it is not available. Some of these operations are also available using the front panel buttons.
- The symbol “” with page number(s) indicates the corresponding reference page(s).
- Notes contain important information about safety and operating instructions.  indicates a tip for your operation.
- This manual is printed prior to production. Design and specifications are subject to change in part as a result of improvements, etc. In case of differences between the manual and the product, the product has priority.

■ Copyright and logo marks

Advanced YST

In 1988, Yamaha brought to the marketplace speaker systems utilizing YST (Yamaha Active Servo Technology) to give powerful, high quality bass reproduction. This technique uses a direct connection between the amplifier and speaker, allowing accurate signal transmission and precise speaker control.

As this technology uses speaker units controlled by the negative impedance drive of the amplifier and resonance generated between the speaker cabinet volume and port, it creates more resonant energy (the “air woofer” concept) than the standard bass reflex method. This allows for bass reproduction from much smaller cabinets than was previously possible.

AirWired **MCR-140**

Real-time uncompressed music transfer without sound degradation is realized by Yamaha original digital wireless transfer technology, AirWired. You can also control turning on/standby and volume with the iPod by AirWired.



English

PARTS

Make sure you have all of the following items.

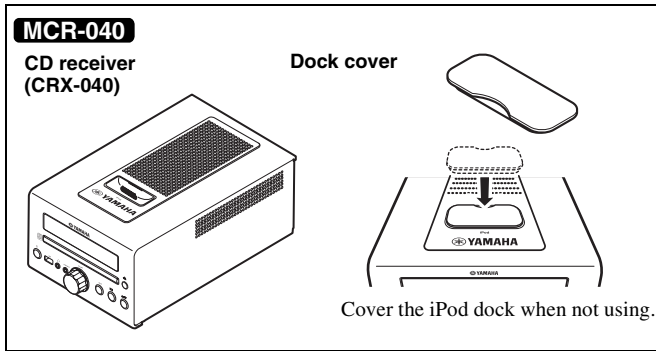

+

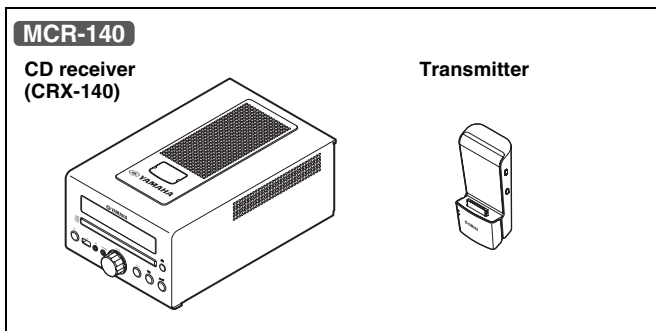
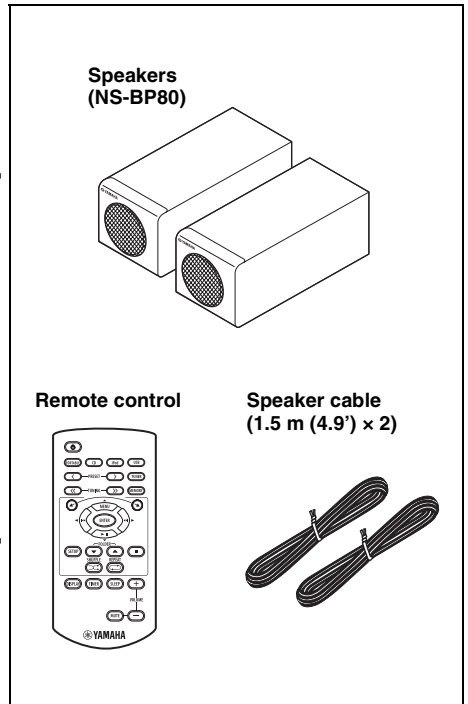

+

■ Using the remote control

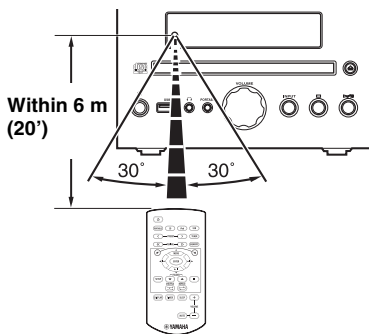

Use the remote control within 6 m (20') of this unit and point it toward the remote control sensor.

Notes

- Do not spill liquid on the remote control.
- Do not drop the remote control.
- Do not leave the remote control in the following places:
 - hot or humid places such as a bathroom or near a heater
 - extremely cold places
 - dusty places

■ Replacing the battery in the remote control

Change the battery when the operation range of the remote control decreases.

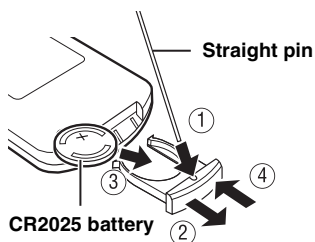

PLAYABLE DISCS AND FILE FORMAT

■ Playable discs

Use compact discs bearing the marks below.



.... **Compact discs (digital audio)**



.... **CD-R, CD-RW digital audio discs**

- CD-R or CD-RW discs bearing one of the following phrases.
FOR CONSUMER
FOR CONSUMER USE
FOR MUSIC USE ONLY



- Finalized CD-R or CD-RW discs

Note

This compact disc player may not be able to play some CD-R/CD-RW discs or discs on which recording was not made correctly.



.... **CD-TEXT discs**



To play back an 8-cm (3 in) CD

Place it in the inner recessed area of the disc tray. Do not put a normal (12-cm) CD on top of an 8-cm (3 in) CD.

To prevent a malfunction of this unit:

- Do not use any nonstandard shaped disc (heart, etc.) available on the market because it might damage the unit.
- Do not use a disc with tape, stickers, or paste on it. If you use such a disc, the disc may get stuck in the unit, or damage to the unit may result.

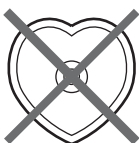

Note: Do not use any lens cleaners as they may be a cause of malfunction.

■ Playable MP3 and WMA files

MP3

Format	Bitrate (kbps)	Sampling frequency (kHz)
MPEG 1 Audio Layer-3	32-320*1	32/44.1/48
MPEG 2 Audio Layer-3, 2	8-160*1	16/22.05/24

*1 Variable bitrate is supported.

WMA

- Version 8
- Version 9 (Standard and variable bitrates are supported. Professional and Lossless are not supported.)

Profile	Bitrate (kbps)	Sampling frequency (kHz)
High Profile	32-320*2	32/44.1/48
Mid Profile	16-32	22.05

*2 Both constant and variable bitrates are supported.

Notes

- Playback for Data Disc starts in alphanumeric order of files.
- Playback for USB starts in order by date and time of creation.
- Copyright-protected WMA (DRM) files cannot be played back by this unit.
- The disc must be ISO 9660 compatible.
- The maximum file and folder numbers are as follows.

	Data Disc	USB
Maximum total number of file and folder*3	512	9,999
Maximum folder number*3	255	255
Maximum file number per folder	511	255

*3 The root is counted as one of the folders.

CONNECTION

Basic connection

Follow the procedure below to connect the speakers.

CAUTION

Do not connect the power cable of this unit until all cable connections are completed.

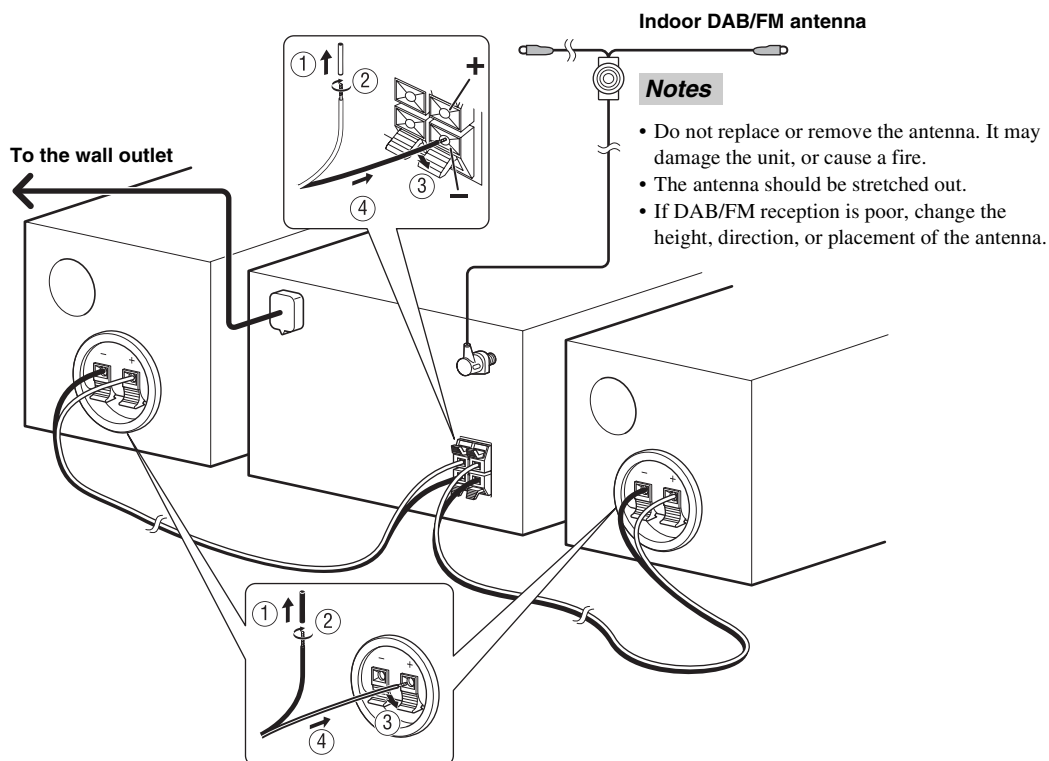

Notes

- Be sure to connect the left channel (L), right channel (R), “+”(red) “-”(black) properly. If the connections are faulty, no sound will be heard from the speakers, and if the polarity of the speaker connections is incorrect, the sound will be unnatural and lacks bass.
- Do not let the bare speaker wires touch each other or do not let them touch any metal part of this unit. This could damage this unit and/or the speakers.
- Use the supplied speakers only. Using different speakers may cause the sound to differ from the intended design.
- There is a chance that placing speakers too close to a CRT-based (Braun tube) TV set might impair picture color. Should this happen, move the speakers away from the TV set.

Wireless connection **MCR-140**

Playback operation with your iPod connected to the transmitter turns the unit on automatically, and you can enjoy the music in your iPod.



To turn on the unit by the playback operation of your iPod, set POWER SAVING to NORMAL (P. 13).

Note

The volume of the unit is adjusted simultaneously with the iPod. Be careful when controlling the volume with your iPod.

Group setting

To operate your iPod using transmitter, you need to match the wireless group between the transmitter and the CD receiver (CRX-140). The default setting for both the transmitter and the CD receiver is A2.

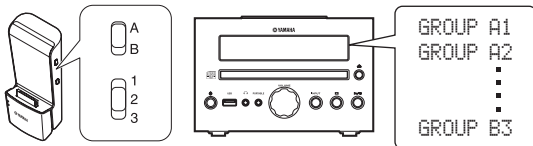

To select wireless group of the CD receiver (CRX-140)

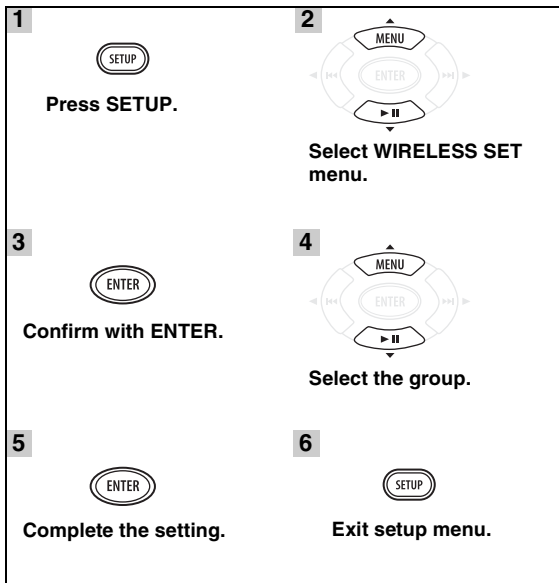

Wireless connection to Subwoofer

You can use a subwoofer wirelessly with the wireless subwoofer kit (SWK-W10, etc., sold separately). To establish the wireless connection, set WIRELESS SW to YES (P. 13). For details, refer to the owner's manual of SWK-W10.

Other connection

Stationing iPod

Station or remove your iPod whenever you want.



Your iPod is automatically charged when your iPod is set in the iPod dock/charging cradle, even if the unit is in standby mode.

Note

The unit is compatible with iPod (5th generation), iPod classic, iPod nano, and iPod touch.

MCR-040

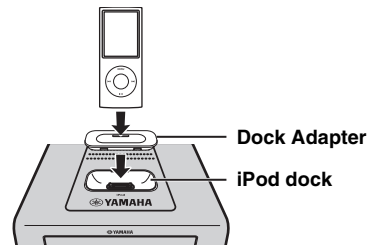

Note

To secure the connection, attach a compatible Dock Adapter supplied with the iPod or an iPod Universal Dock Adapter (sold separately), and remove the protective case covering your iPod.

MCR-140

Station your iPod in the charging cradle when you want to charge your iPod. You can also control your iPod with the remote control when your iPod is in the charging cradle.

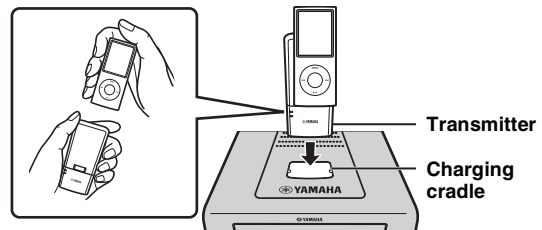

Connecting USB

Connect or remove your USB device whenever you want.

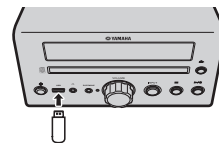

USB device is automatically charged when it is connected to the unit, even if the unit is in standby mode.

Notes

- This unit supports USB mass storage class devices (e.g., flash memories or portable audio players) using FAT16 or FAT32 format.
- Do not connect devices other than USB mass storage class devices (such as USB chargers or USB hubs), PCs, card readers, an external HDD, etc.

REMOTE CONTROL

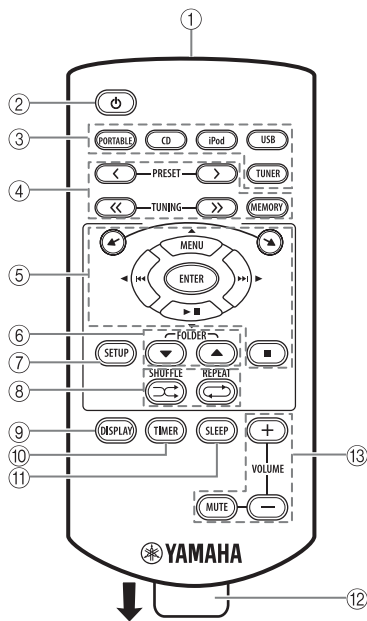

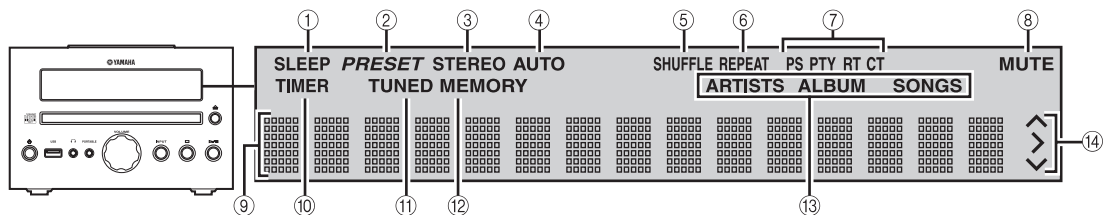

- ① Infrared signal transmitter (☞ P. 2)
- ② ⏻: standby/on
- ③ Source buttons: PORTABLE, CD, iPod, USB (☞ P. 8, 12)
- ④ DAB/FM control buttons (☞ P. 10, 12)
- ⑤ ▲/▼: iPod scroll buttons (☞ P. 8)
 MENU/ENTER/▶/⏸/◀/▶▶: multi function buttons (☞ P. 8, 9, 12, 13)
 ■ : Stop button (☞ P. 8, 9)
- ⑥ FOLDER ▼/▲ (☞ P. 8)
- ⑦ SETUP (☞ P. 5, 13, 15)
- ⑧ SHUFFLE/REPEAT (☞ P. 9)
- ⑨ DISPLAY (☞ P. 9, 11, 12, 14)
- ⑩ TIMER (☞ P. 14, 16)
- ⑪ SLEEP (☞ P. 16)
- ⑫ Battery insulation sheet: Remove before using.
- ⑬ Volume control buttons: Press to control the volume.
 Press MUTE to turn off the sound. Press again to resume the volume.

FRONT PANEL DISPLAY



- ① SLEEP indicator: Lights up when the sleep timer is on (☞ P. 16).
- ② PRESET indicator: Lights up when you preset radio stations (☞ P. 10, 12).
- ③ STEREO indicator: Lights up when this unit is receiving a strong signal from a DAB/FM stereo broadcast.
- ④ AUTO indicator: Lights up when this unit is in the Automatic Tuning mode (☞ P. 12).
- ⑤ SHUFFLE indicator: Lights up when you set your iPod (MCR-040)/CD/USB to shuffle play (☞ P. 9).
- ⑥ REPEAT indicator: Lights up when you set your iPod (MCR-040)/CD/USB to repeat play (☞ P. 9).
- ⑦ Radio Data System indicators: The name of the Radio Data System data offered by the currently received Radio Data System station lights up (☞ P. 12).
- ⑧ MUTE indicator: Lights up when the sound is muted.
- ⑨ Multi information display: Shows the various information such as the tuning frequency.
- ⑩ TIMER indicator: Flashes during timer setting. Lights up when the timer is on (☞ P. 16).
- ⑪ TUNED indicator: Lights up when this unit is tuned into a station (☞ P. 10, 12).
- ⑫ MEMORY indicator: Flashes when searching for a radio station by automatic preset tuning. Lights up when you preset radio stations automatically or manually (☞ P. 12).
- ⑬ Multi information indicator: Indicates the music information currently displayed on Multi information display (☞ P. 9).
- ⑭ Operation indicators: Shows operable multi function buttons for a currently selected SETUP item.

FRONT PANEL AND BASIC OPERATION

- ☀️ This unit has an automatic standby function, which will automatically switch the unit to standby mode if the unit is left turned on for 1 hour without playback or any other operation being performed. This function is not available when the source is set to PORTABLE/DAB/FM.
- ⏻ Press  to set the unit to standby mode. All the information on the front panel display is not displayed in standby mode. This can reduce power consumption. To turn on the unit, press , or start playback with your iPod connected to the transmitter (MCR-140 only).
- ⏻ If the iPod selected as the input source is disconnected from the transmitter, or does not output sound for a certain period, the unit will automatically switch to standby mode (MCR-140 only).

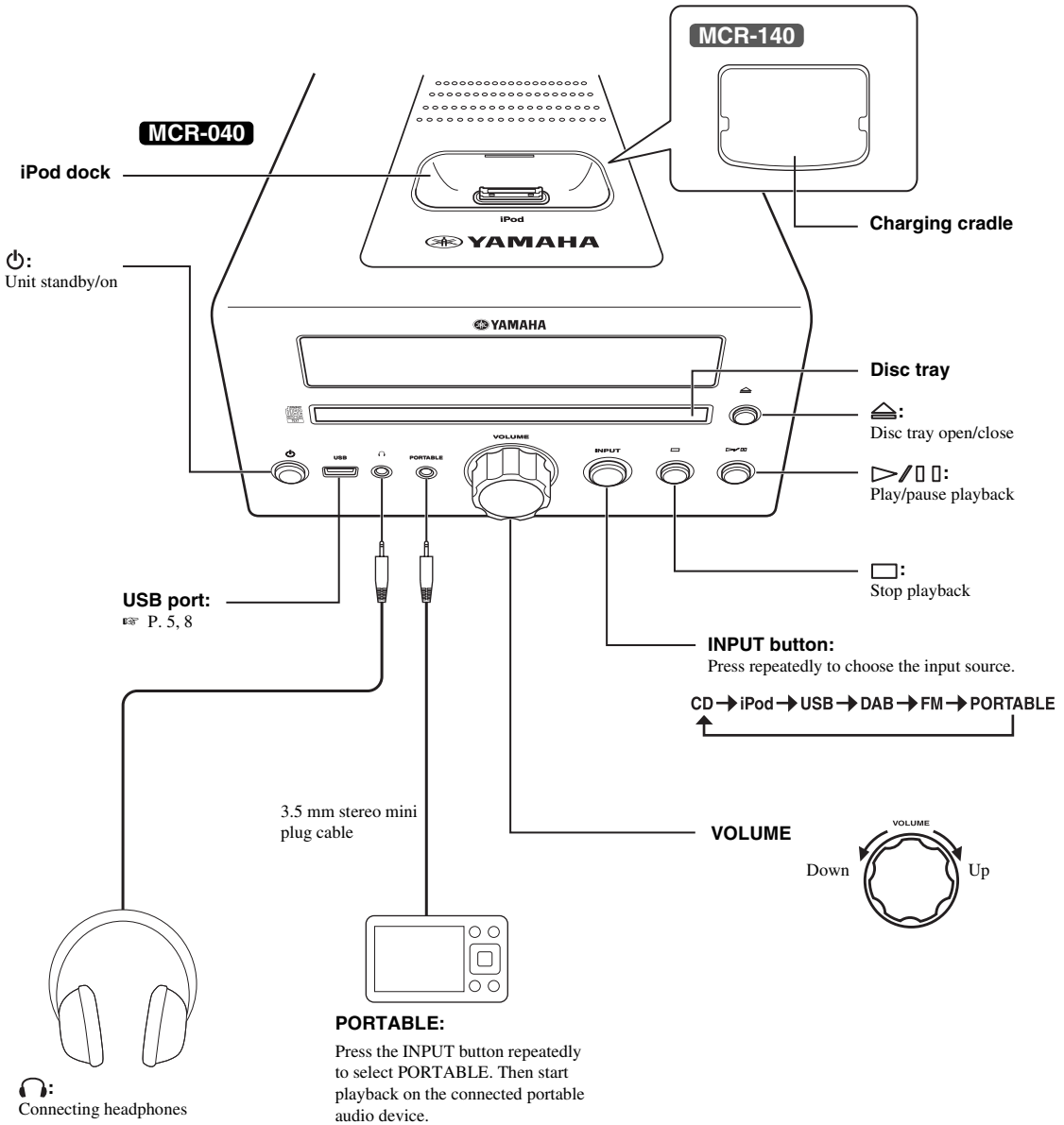

 Connecting headphones

No sound is output from the speakers when headphones are connected.

LISTENING TO MUSIC

Playback operation

Follow the procedures below to play back music.

	1 Set the source	2 Switch the input	3 Select music and start playback
iPod*1	<p>MCR-040</p> <p>Dock Adapter</p> <p>P. 5</p>	<p>iPod</p>	<p>Scroll the list</p> <p>Control menu</p> <p>For the MCR-140, the operation on the remote control or front panel is available only when your iPod is stationed in the charging cradle (P. 5).</p>
	<p>MCR-140</p> <p>Status indicator</p> <p>P. 5, 19</p>		<p>MCR-140</p> <p>Control with iPod</p> <p>Be careful when controlling the volume (P. 5).</p>
CD		<p>CD</p>	
USB*2	<p>P. 5</p>	<p>USB</p>	<p>Skip to the first file in the previous/next folder for MP3 or WMA*3</p>

*1 Some features may not be available depending on the model or the software version of your iPod.

*2 • Some devices may not work properly even if they meet the requirements.

- Playability of and power supply to all kind of USB devices are not guaranteed.
- The reading time may exceed 30 seconds depending on the number of files/folders.
- Yamaha and suppliers accept no liability for the loss of data saved on the USB devices connected to this unit. As a precaution, it is recommended that the files are made backup copies.

*3 If you press these buttons during playback, the folder name is displayed on the front panel display for a certain period.

Other operation

Control playback

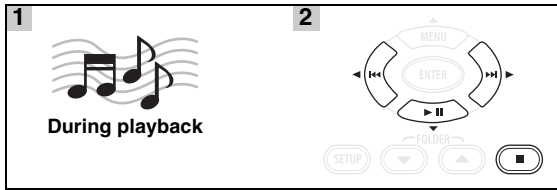

- ▶▶: Skip forward/Press and hold to Fast forward
- ◀◀: Skip backward/Press and hold to Rewind
- ▶||: Play/Pause
- : Stop

Notes

- Playback for Data Disc starts in alphanumeric order of files.
- Playback for USB starts in order by date and time of creation.

Shuffle play

You can play back in random sequence.



For iPod

OFF → SONGS → (ALBUMS)*1

*1 You cannot set ALBUMS when you use an iPod touch.

For CD/USB

OFF → (FOLDER)*2 → ALL

*2 If the audio format of the selected music source is MP3/WMA, you can also select FOLDER.

Repeat play

You can play back repeatedly.



OFF → ONE → (FOLDER)*3 → ALL

*3 If the audio format of the selected music source is MP3/WMA, you can also select FOLDER.

Switching the display

You can switch the playback information shown on the front panel display. Some special characters may not be shown properly.

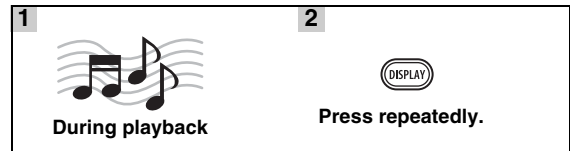

For iPod (MCR-040)

Song number and elapsed time (default setting)

↓

Song number and remaining time

↓

Song name

↓

Artist name

↓

Album name

↓

Back to the default setting

Note

This function is available for iPod (5th generation), iPod classic, iPod nano, and iPod touch. However, even with these models, this function may not be available depending on the software version of your iPod.

For CD/USB

Track/file number and elapsed time of the current song (default setting)

↓

Track number and remaining time of the current song*4

↓

Total time of the disc*4

↓

Remaining time of the disc*4

↓

File name*5

↓

Track name*6

↓

Artist name*6

↓

Album name*6

↓

Back to the default setting

*4 Only for Audio CDs

*5 Only for MP3/WMA files

*6 Only when the selected track has information

LISTENING TO DAB STATIONS

DAB (Digital Audio Broadcasting) uses digital signals for clearer sound and more stable reception compared to analog signals.

This unit can also receive DAB+ (an upgraded version of DAB) that allows for more stations using MPEG-4 audio codec (AAC+), which has a more efficient transmission method.

Preparing the DAB tuning

Before tuning into DAB stations, an initial scan must be performed. The initial scan starts automatically when you select DAB as the input source for the first time.

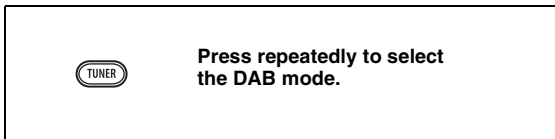

You can also perform the initial scan manually by INIT SCAN (P. 13, 15).

While the scan is in progress, “Scanning” and the percentage of the progress of scan appear on the front panel display.



When scanning is complete, the number of receivable DAB stations appears on the front panel display for a while, then the unit airs the first station as stored in station order.

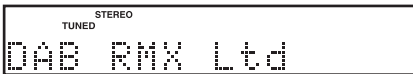
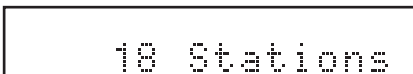

Note

This unit can receive Band III (174 - 240 MHz) only.

Tuning DAB stations

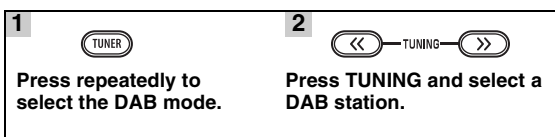

Some stations have sub (secondary) stations. The secondary indicator lights up when a secondary audio station is selected.



Secondary indicator

You can change the order of DAB stations by STATION ORDER (P. 13, 15).

Note

When the unit cannot receive the DAB signal, “Off Air” is displayed on the front panel display.

Presetting DAB stations

You can store your favorite DAB stations with the preset function. The PRESET indicator lights up on the front panel display (P. 6).

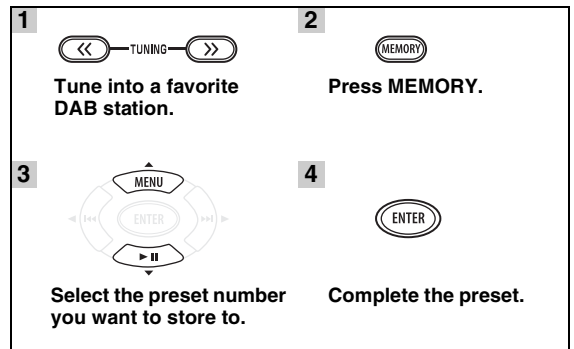

- You can preset up to 30 DAB stations.
- To cancel the preset while choosing a preset number, press **MEMORY** again.
- You can delete a preset station by pressing **SETUP** → **MENU** → **ENTER** to select PRESET DELETE.

Selecting preset DAB stations (Preset tuning)

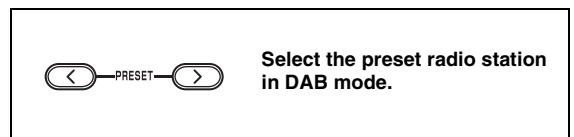

DAB station information

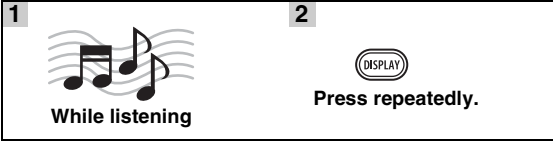

STATION LABEL

Displays the name of the current DAB station and preset number.



DLS (Dynamic Label Segment)

Displays information about the current DAB station, such as the name of the song, artist and speaker, etc. This data is continuously updated by the DAB broadcaster, thus changing often with every new song or program.

Other data, such as news, weather, and sports headlines, may be broadcast as well.



ENSEMBLE LABEL

Displays the name of the current ensemble.



PROGRAM TYPE

Displays the genre of the current DAB station.



TIME

Displays the current time.



BITRATE

Displays the bitrate of the current DAB station.



CHANNEL/FREQ

Displays the channel label and frequency of the current DAB station.



SIGNAL QUALITY

Displays signal reception quality (from 0 (none) to 100 (best)) of current DAB tuning.



AUDIO FORMAT

Displays the audio format of the current station, and whether DRC (Dynamic Range Control)* is activated. "(DRC ON)" is displayed when DRC MODE (P. 13, 15) is set to AUTO and DRC information is transmitted by DAB station.

* Some DAB broadcasters transmit a wide dynamic range enabling high quality sound, accompanied by DRC information.

Use this feature to compress the dynamic range of the DAB broadcast. This is especially useful when you listen to a DAB station in a noisy environment or at low volume at night.



You can change the DRC setting by DRC MODE (P. 13, 15).



Back to the STATION LABEL

Note

Not all DAB broadcasters transmit station information.



DAB frequency information

This unit can receive Band III only.

Frequency	Channel label
174.928 MHz	5A
176.640 MHz	5B
178.352 MHz	5C
180.064 MHz	5D
181.936 MHz	6A
183.648 MHz	6B
185.360 MHz	6C
187.072 MHz	6D
188.928 MHz	7A
190.640 MHz	7B
192.352 MHz	7C
194.064 MHz	7D
195.936 MHz	8A
197.648 MHz	8B
199.360 MHz	8C
201.072 MHz	8D
202.928 MHz	9A
204.640 MHz	9B
206.352 MHz	9C
208.064 MHz	9D
209.936 MHz	10A
211.648 MHz	10B
213.360 MHz	10C
215.072 MHz	10D
216.928 MHz	11A
218.640 MHz	11B
220.352 MHz	11C
222.064 MHz	11D
223.936 MHz	12A
225.648 MHz	12B
227.360 MHz	12C
229.072 MHz	12D
230.784 MHz	13A
232.496 MHz	13B
234.208 MHz	13C
235.776 MHz	13D
237.488 MHz	13E
239.200 MHz	13F

LISTENING TO FM STATIONS

Tuning to FM stations

1  Press repeatedly to select the FM mode.	2  Press and hold. Automatic tuning starts.
---	--

 If the signal received from the station you want to select is weak, you can also tune into FM stations manually by pressing **TUNING** </> repeatedly.



Note

If you tune to a station manually, the sound is monaural.

Presetting FM stations

You can store your favorite FM stations with the preset function.





■ Automatic preset tuning

1  Press and hold MEMORY for more than 2 seconds in FM mode.	2  Start the automatic preset.
---	---

Note

When you perform the automatic preset, all stored stations are cleared and the new stations are stored.

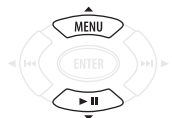
■ Manual preset tuning



1  Tune into a favorite FM station.	2  Press MEMORY.
3  Select the preset number you want to store to.	4  Complete the manual preset.

- 
- You can preset up to 30 FM stations.
 - To cancel the manual preset while choosing a preset number, press **MEMORY** again.
 - You can delete a preset station by pressing **SETUP** → **MENU** → **▲/▼** → **ENTER** to select PRESET DELETE.

Selecting preset FM stations (Preset tuning)

	Select the preset radio station in FM mode.
---	--

Displaying Radio Data System information (U.K. model only)

1  While listening	2  Press repeatedly.
---	---

PS (Program Service)



PTY (Program Type)



RT (Radio Text)



CT (Clock Time)



Frequency



Back to the PS

Note

If the signal transmission of the Radio Data System station is too weak, this unit may not be able to receive Radio Data System information completely. In particular, RT (Radio Text) information uses a lot of bandwidth, so it may be less available compared to other types of information.

USING USEFUL FUNCTIONS

Using setup menu

The setup menu appears on the front panel display by pressing **SETUP**. You can set various useful functions with setup menu.

Setup menu	Parameter or control range	Reference page
PRESET DELETE*1	(Displays only when the input source is set to DAB/FM.)	12, 15
STATION ORDER*1	ALPHANUMERIC/ENSEMBLE (Displays only when the input source is set to DAB.)	15
DRC MODE*1	AUTO/OFF (Displays only when the input source is set to DAB.)	15
DAB CLEAR*1	(Displays only when the input source is set to DAB.)	15
INIT SCAN	(Displays only when the input source is set to DAB.)	15
TUNE AID	(Displays only when the input source is set to DAB.)	15
DIMMER	DIMMER ON (25%)/OFF (100%)	14
TREBLE	-6 dB to +6 dB	14
BASS	-6 dB to +6 dB	14
BALANCE	L+5 - CENTER - R+5	14
AUTO CLOCK	ON/OFF	14
CLOCK SET	Hour, minute	14
TIMER SET	Time (hour, minute), running time, sound (source, track or preset number), timer on/off	14
WIRELESS SET MCR-140	GROUP A1/A2/A3/B1/B2/B3	5
POWER SAVING MCR-140	NORMAL/ECO	14
WIRELESS SW MCR-140	NO/YES	14

*1 When the input source is set to DAB, and if the unit cannot receive any DAB stations, these setup menus do not appear.

■ Operation procedure

For DAB CLEAR, INIT SCAN and TUNE AID, see page 15.

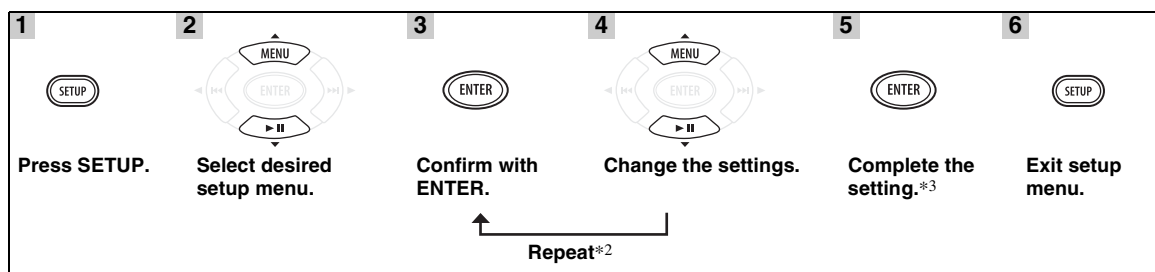

*2 When there are some parameters to set, repeat steps 3 and 4. You can go back to a previous parameter by pressing **◀◀**.

*3 To set additional items, repeat steps 2 to 5.



To cancel the setting during the operation, press **SETUP**.

■ **Setting dimmer, tone/balance and power saving mode**

DIMMER: Changes the brightness of the front panel display.

TREBLE*: Adjusts the high frequency response.

BASS*: Adjusts the low frequency response.

BALANCE: Adjusts the volume level of each left and right speaker channel.

POWER SAVING: If you set to ECO, you can reduce standby power consumption. However, you cannot turn on the unit by playback operation on your iPod during standby mode. The default setting is NORMAL. This function is available only for MCR-140.

WIRELESS SW: Set to YES when you use a subwoofer via the wireless subwoofer kit (SWK-W10, etc., sold separately). The default setting is NO. This function is available only for MCR-140.

* Also effective when you are using headphones.

■ **Adjusting the clock**

AUTO CLOCK: Automatic adjustment function is available for Europe, U.K. and Australia models only. To apply for this function, set AUTO CLOCK to ON.

CLOCK SET: To set hour and minute, repeat steps 3 and 4 on page 13.



The current time appears on the front panel display for a certain period by pressing and holding **DISPLAY** if the time setting has completed.

Note

The time setting is lost once the power cable is disconnected from the wall outlet.

■ **Setting the timer**

TIMER SET: To select the following setting items, repeat steps 3 and 4 on page 13.



You can enter **TIMER SET** directly by pressing and holding **TIMER**.

Time (hour and minute)



Running time



You can choose the running time from 10 minutes to 90 minutes in 10 minute increments. “--” means the unit will not be set to standby mode automatically.

Input source and track/file number or preset number

Notes

- If the source is not set properly, the timer sound will not be heard. Make sure that the source is set securely.
- MCR-140: When you select an iPod as the input source, you need to set the iPod in the charging cradle on the unit.

iPod:

When you select the iPod as a source, this unit resumes the music that you were listening to last time.

CD:

Set a track/file number.

If you set the track/file number which is not exist, the first track/file is played back automatically.

FM:

Set preset number.

By selecting “--”, the FM station you set last time is set.

DAB:

Set preset number.

By selecting “--”, the DAB station you set last time is set.

USB:

Set a file number.

If you set a file number that does not exist, the first file is played back automatically.

Timer ON/OFF

Switch the timer on/off. When the timer is on, the **TIMER** indicator lights up on the front panel display (☀ P. 6).



This setting is also available with **TIMER** (☀ P. 6, 16).

Using DAB option menu

■ Performing DAB CLEAR and INIT SCAN

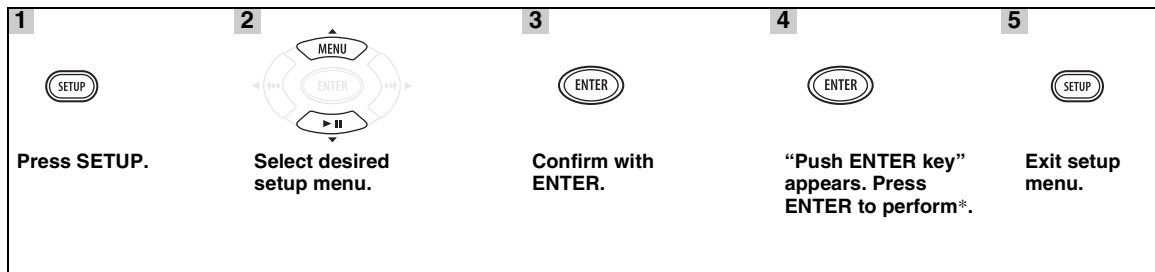

DAB CLEAR: Deletes all DAB station information and preset settings stored in the unit. After DAB CLEAR is complete, the unit moves to the INIT SCAN functions automatically. Note that once DAB CLEAR is performed, the deleted information and preset settings cannot be restored.

INIT SCAN: Performs the initial scan manually. Each time you perform INIT SCAN, the newly received stations are added to the previously received stations.

* After performing INIT SCAN, the unit airs the first station as stored in station.

■ Using TUNE AID

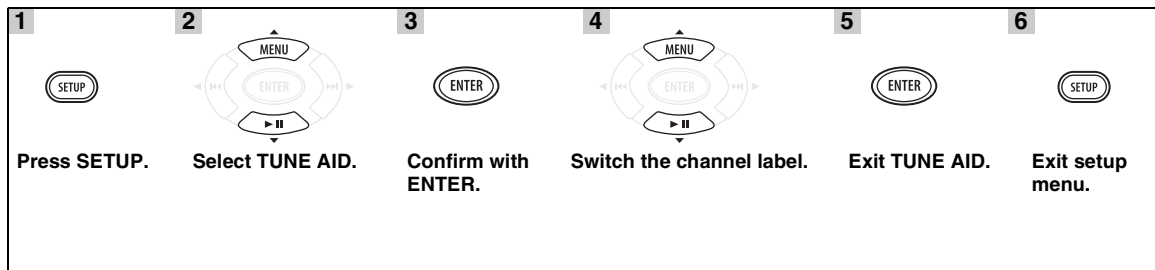

TUNE AID: Measures reception strength of the received DAB signal (from 0 (none) to 100 (best)). Adjust the DAB/FM antenna to find the best position to receive the DAB signal.



To check the frequency corresponding to the channel label, refer to “DAB frequency information” on page 11.

■ Setting STATION ORDER and DRC MODE

Follow the operation procedure on page 13.

STATION ORDER: Enables you to change the station order. Set to **ENSEMBLE** to list the stations in ensemble order. The default setting is **ALPHANUMERIC**.

DRC MODE: Changes the DRC (☀ P. 11, 13) setting. This function utilizes DRC automatically if it is transmitted. The default setting is **AUTO**.

Using timer and sleep timer

■ Using the timer

The timer sets the unit to play back music at the time you set. The unit is set to standby mode after the specified running time elapses.

To use the timer, set the appropriate input source securely and set the timer in the setup menu in advance (P. 14).

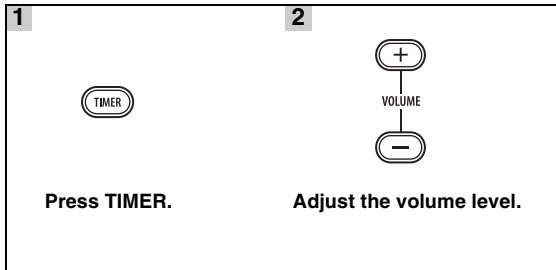

Each time you press **TIMER** while the power is on, it switches on/off. When you switch on the timer, the **TIMER** indicator lights up on the front panel display (P. 6). To turn on the unit via the timer, set this unit to standby mode when the timer is switched on.

Notes

- The clock has to be set in advance.
- When the unit is in standby mode, the **TIMER** indicator does not light up on the front panel display even if the timer is on.
- After the unit is operated via the timer, the timer function switches off.



- To activate the timer function again, press **TIMER** while the power is on.
- The timer setting is saved for convenient use next time.

■ Using sleep timer

The sleep timer sets the unit to the standby mode after the specified time elapses.



OFF → 30min → 60min → 90min → 120min

The **SLEEP** indicator lights up on the front panel display (P. 6).

TROUBLESHOOTING

Refer to the table below when this unit does not function properly. If the problem you are experiencing is not listed below or if the instruction below does not help, turn off this unit, disconnect the power cable, and contact the nearest authorized Yamaha dealer or service center.

General

Problem	Cause	Remedy	Page
This unit fails to turn on or enters the standby mode soon after the power is turned on.	The power cable is not connected or the plug is not completely inserted.	Connect the power cable firmly.	4
	This unit has been exposed to a strong external electric shock (such as lightning or strong static electricity).	Set this unit to the standby mode, disconnect the power cable, plug it back in after 30 seconds and then use it normally.	—
The unit does not operate properly.			
No sound.	No appropriate input source has been selected.	Select an appropriate input source with INPUT on the front panel (or the source buttons on the remote control).	—
	Speaker connections are not secure.	Secure the connections.	4
	The mute function may be on.	Cancel the mute function.	6
	The volume is turned down.	Turn up the volume.	—
	Signals this unit cannot reproduce are being input from a source component, such as a CD-ROM.	Play a source whose signals can be reproduced by this unit.	3
The power is suddenly turned off.	The sleep timer may be set.	This is not malfunction. Turn on the unit and play the source again.	—
	The unit is left turned on for 1 hour without playback or any other operation being performed.		
	The power was turned on by the timer and elapsed specified running time.		
	MCR-140: The iPod selected as the input source is disconnected from the transmitter, or does not output sound for a certain period.		
The clock setting has been cleared.	The power cable has been disconnected.	Connect the power cable, and set the clock again.	—
Sound is heard from the speaker on one side only.	Incorrect cable connections.	Connect the cables properly. If the problem persists, the cables may be defective.	4
There is noise interference from digital or radio frequency equipment.	This unit is too close to the digital or high-frequency equipment.	Move this unit farther away from such equipment.	—

The following status messages appear only if you are using MCR-140.

Status message	Cause	Remedy	Page
Subwoofer Link	Wireless connection between the subwoofer and the unit is established.		
SubwooferUnlink	Wireless connection between the subwoofer and the unit is disconnected.		
Wireless Error	There is a problem with the internal circuit of this unit.	Disconnect the power cable and contact the nearest authorized Yamaha dealer or service center.	—

DAB reception

Problem	Cause	Remedy	Page
Cannot tune into any DAB stations.	The initial scan operations were not performed.	Perform the initial scan operations	13, 15
	There is no DAB coverage in your area.	Check with your dealer or WorldDMB online at http://www.worlddab.org for a listing of the DAB coverage in your area.	—
	The DAB signals are too weak.	Use the TUNE AID feature to locate the best positioning of the indoor DAB/FM antenna.	13, 15
The initial scan operations are not successful and “Not found” appears on the front panel display.	The DAB signals are too weak.	Use the TUNE AID feature to locate the best positioning of the indoor DAB/FM antenna.	13, 15
	There is no DAB coverage in your area.	Check with your dealer or WorldDMB online at http://www.worlddab.org for a listing of the DAB coverage in your area.	—
The DAB station reception is weak.	The positioning of the indoor DAB/FM antenna and/or this unit is not optimal for DAB reception.	Use the TUNE AID feature to locate the best positioning of the indoor DAB/FM antenna and this unit for optimal DAB reception	13, 15
	The DAB signals are too weak.	Use the TUNE AID feature to locate the best positioning of the indoor DAB/FM antenna.	13, 15
There is noise interference (e.g. hiss, crackle or jitter)	The indoor DAB/FM antenna needs to be repositioned.	Readjust the position of the indoor DAB/FM antenna.	4
	The DAB signals are too weak.	Use the TUNE AID feature to locate the best positioning of the indoor DAB/FM antenna.	13, 15
The DAB station information does not appear or is inaccurate.	The DAB station may be temporarily out of service, or the DAB station information is not provided by the DAB broadcaster.	Contact the DAB broadcaster.	—

FM reception

Problem	Cause	Remedy	Page
FM stereo reception is noisy.	The characteristics of FM stereo broadcasts may cause this problem when the transmitter is too far away or the antenna input is poor.	Change the height, direction, or placement of the antenna.	—
		Use the manual tuning method.	12
The desired station cannot be tuned into with the automatic tuning method.	The signal is too weak.	Change the height, direction, or placement of the antenna.	—
		Use the manual tuning method.	12
The preset selecting function does not work.	The preset (memory) may have been erased.	Preset FM stations again.	12

iPod™

Note

In case of a transmission error without a status message appearing in the front panel of this unit, check the connection to your iPod (see page 5).

The following status messages appear only if you are using MCR-040.

Status message	Cause	Remedy	Page
iPod Connecting iPod Charging	This unit is in the middle of recognizing the connection with your iPod.	If the message continues to appear in the front panel display and playback does not start, connect the iPod again.	—
Unknown iPod	There is a problem with the signal path from your iPod to this unit.	Connect the iPod again.	5
	The iPod being used is not supported by this unit.	Only iPod (5th generation), iPod classic, iPod nano, and iPod touch are supported.	—
iPod	This unit has recognized your iPod; however, it cannot obtain information such as elapsed time.		
iPod Unplugged	Your iPod was removed from the iPod dock.	Station your iPod back in the iPod dock.	5

The following status messages appear only if you are using MCR-140.

Status message	Cause	Remedy	Page
iPod Linked iPod	Wireless connection was successful.		
iPod Unlinked	Wireless connection has disconnected.	Connect the iPod to the transmitter and start playback.	5
iPod Low Batt.	The battery of the iPod is getting flat.	Set it in the charging cradle.	5

The following LED statuses of the status indicator refer to the transmitter.

LED status	Transmitter status	Remedy	Page
Off	The transmitter is in standby mode.		
	An iPod is not connected or wireless communication has not been established.		
Flashes green	Connection in progress.	Please wait.	—
Flashes green once	Adjusting the volume level or operating with the remote control.		
Lights up green	Wireless communication between the unit and transmitter is established.		
Lights up green and flashes red for 2 seconds	An unsupported iPod is connected.	Only iPod (5th generation), iPod classic, iPod nano, and iPod touch are supported.	5
Lights up green and keeps flashing red	Connection failed.	Connect again.	8
Flashes red	Error occurs.	Remove the iPod from the transmitter, and connect again.	8
Flashes red once	The volume of the unit is set to maximum or minimum.		
Flashes red 2 times continuously (regardless of green status)	The battery of the iPod is low.	Set the iPod in the charging cradle.	5

Problem	Cause	Remedy	Page
No sound.	The power of the unit is off.	Connect the power cable correctly.	—
	The iPod software version has not been updated.	Download the latest iTunes software to update the iPod software version to the latest.	—
	The iPod is in the process of connecting with the unit.	Please wait for a while.	—
	MCR-140: The battery of the iPod is low.	Charge the iPod.	—
	MCR-140: The iPod is not connected to the transmitter firmly.	Connect the iPod firmly.	—
	MCR-140: Earphones are connected to the iPod.	Remove the earphones.	—
	MCR-140: The signal from the transmitter is blocked by your body or metallic objects, etc.	Change the way of holding, the orientation, or the position of the transmitter to avoid your body or metallic objects blocking the signal.	—
	MCR-140: There is a device (microwave oven, wireless LAN, cordless telephone, etc.) outputting signals in the 2.4 GHz frequency band nearby.	Place the unit away from these devices, or turn them off. If the device is IEEE802.11n-compliant, change the channel setting of the device so as not to affect the unit.	—
	MCR-140: Distance is too far.	Move the transmitter closer to the unit. Transmission range is approximately 10 m (32.8 ft). Also, placing the unit in a lower position makes it easier to receive wireless signals.	—
	MCR-140: The unit and transmitter are not connected since they are set to different groups.	Set both the unit and transmitter to the same group.	5
MCR-140: The unit is connected to another unit.	Select a different group by changing the group setting of the unit and transmitter.	5	
No sound.	MCR-040: The iPod is set in the iPod dock improperly.	Remove the iPod from the unit, then set it in the iPod dock again.	5
The iPod sounds, but you cannot operate it with the unit or the remote control.	MCR-140: The iPod is not connected to the transmitter properly.	Remove the iPod from the transmitter, then set it to the transmitter again.	5
	Cannot change the volume by changing the volume of the iPod.	The iPod is not supported by this unit.	Only iPod (5th generation), iPod classic, iPod nano, and iPod touch are supported.
The iPod display does not change by pressing the remote control volume keys.	The iPod is not connected correctly.	Connect the iPod firmly.	—
	The iPod software version is out of date.	Update the iPod software version to the latest. If the problem cannot be solved, even with the latest software, reset the iPod.	—
	The unit cannot be operated by the remote control.		
You cannot operate from the iPod.	MCR-040: The iPod is set in the iPod dock improperly.	Remove the iPod from the unit, then set it in the iPod dock again.	5
	MCR-140: The iPod is connected to the transmitter improperly.	Remove the iPod from the transmitter, and connect to the transmitter again, then start playback.	8
The playback information is not displayed on the front panel display.	The iPod you set is not compatible with the playback information display.	Only iPod (5th generation), iPod classic, iPod nano, and iPod touch are supported.	5
	You are using MCR-140.	Only MCR-040 is available for playback information display.	—
The iPod does not charge up.	MCR-040: The iPod is set in the iPod dock improperly.	Remove the iPod from the unit, then set it in the iPod dock again.	5
	MCR-140: The iPod is set in the charging cradle improperly.	Remove the iPod from the unit, then set it in the charging cradle again.	5

Problem	Cause	Remedy	Page
Suddenly the speaker produces sound even though an iPod is not connected.	MCR-140: The unit is connected to another transmitter.	Change the group setting.	5
Transmitted sound is cut.	MCR-140: If noise occurs at the same frequency the transmitter is using, the unit will search and move to another (unused) frequency, which may cause sound to be cut.	This is not malfunction. If cut occurs frequently, relocate the unit.	—

USB

Note

In case of a transmission error without a status message appearing in the front panel of this unit, check the connection to the USB device (see page 5).

Status message	Cause	Remedy	Page
USB Unplugged	The USB device is not connected firmly.	Connect the USB device again.	5
Unknown USB	The connected USB device is not playable on this unit.	Connect playable USB device.	5
USB OverCurrent	The connected USB device is not playable on this unit. The USB device is connected at an angle.	Disconnect the USB device. Change input source other than USB and select USB as input source again. Then connect playable USB device again.	5

Problem	Cause	Remedy	Page
MP3/WMA file in the USB device does not play.	The USB device is not recognized.	Connect the USB device again.	5
		Connect an AC adapter if supplied with the device.	—
	Improper USB device connections.	Connect the USB device again.	5
	The MP3 or WMA formats are not compatible with this unit.	Replace the file with a correctly recorded file playable with this unit.	3
	If the solutions above do not resolve the problem, the USB device is not playable on the unit.	Try another USB device.	—

Disc playback

Problem	Cause	Remedy	Page
No sound or distorted sound	The sampling rate of an MP3 or WMA file may not be compatible with this unit.	Check the sampling rate and bit rate of an MP3 or WMA file are compatible with this unit.	3
Disc playback does not start.	You may be using a CD-R/RW that is not finalized.	Finalize the CD-R/RW.	—
	The disc label may be upside down.	Check that the disc label is facing up.	—
	The disc may be defective.	Try playing back another disc. If this cures the problem, the disc you want to play back is defective.	—
	MP3/WMA disc may not contain sufficient music files to be played back.	Check that your MP3/WMA disc contains at least 5 MP3/WMA music files. If the number of files is small, the disc may not be recognized.	—
	The sampling rate of an MP3 or WMA file may not be compatible with this unit.	Check the sampling rate and bit rate of an MP3 or WMA file are compatible with this unit.	3
Some button operations do not work.	The disc loaded into the unit may not be compatible.	Remove the disc and then check whether the unit supports the disc or not.	3
Playback does not start immediately after pressing \triangleright/\square on the unit or \blacktriangleright \square on the remote control.	The disc may be dirty.	Wipe the disc clean.	—
	The disc loaded into the unit may not be compatible.	Use a disc supported by the unit.	3
	If the unit was moved from a cold to warm place, condensation may have formed on the disc reading lens.	Wait for an hour or two until the unit adjusts to the room temperature, and try again.	—
“No Disc” appears in the display even though a disc is in the disc tray.	The disc loaded into the unit may not be compatible.	Use a disc supported by the unit.	3
	The disc may be dirty.	Remove the disc and then wipe the disc clean.	—
	Disc is loaded upside-down.	Remove the disc and then load the disc with the labeled side facing up.	—

Remote control

Problem	Cause	Remedy	Page
The remote control does not work nor function properly.	The remote control may be operated outside its operation range.	For information on the remote control operation range, refer to “Using the remote control”.	2
	The remote control sensor on this unit may be exposed to direct sunlight or lighting.	Change the lighting or orientation of this unit.	—
	The battery may be worn out.	Replace the battery with new one.	2
	There are obstacles between the sensor of this unit and the remote control.	Remove the obstacles.	—

HANDLING COMPACT DISCS

- Always handle with care so that the playing surface is not scratched. Do not bend discs.

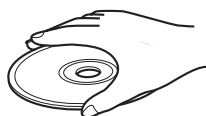

- To keep the playing surface clean, wipe with a clean, dry cloth. Do not use any type of disc cleaner, spray, or any other chemical-based liquid.
- Do not expose discs to direct sunlight, high temperature or high humidity for a long time.

- Do not wipe with a circular motion; wipe straight outward from the center.

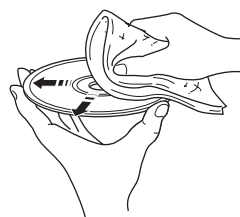

- Use a soft-tipped pen when writing on the label side of a disc.

SPECIFICATIONS

■ CD RECEIVER (CRX-040, CRX-140)

PLAYER SECTION

iPod

- Supported iPod.....iPod (5th generation), iPod classic, iPod nano, iPod touch

CD

- MediaCD, CD-R/RW
- Audio format..... Audio CD, MP3, WMA

LASER

- TypeSemiconductor laser GaAs/GaAlAs
- Wave length780 nm
- Output power10 mW

USB

- Audio format.....MP3, WMA

PORTABLE

- Input connector STEREO L/R: 3.5 mm STEREO mini Jack

AMPLIFIER SECTION

- Maximum output power15 W + 15 W
(6 Ω 1 kHz, 10% THD)

Input sensitivity

- PORTABLE..... 450 mV/22 kΩ

Total harmonic distortion

- CD etc. 1 kHz/1W..... 0.05 %

TUNER SECTION

Tuning range

- DAB 174 to 240 MHz (Band III)

FM

- [U.S.A. and Canada models] 87.5 to 107.9 MHz

- [Other models]..... 87.50 to 108.00 MHz

GENERAL

Power supply

- [Europe model]AC 230 V, 50 Hz

- [U.S.A. and Canada models]AC 120 V, 60 Hz

- [Asia model] AC 220/230-240 V, 50/60 Hz

- [Taiwan model]..... AC 110/120 V, 60 Hz

- [Australia model]AC 240 V, 50 Hz

- [U.K. model].....AC 230 V, 50 Hz

- [China model]AC 220 V, 50 Hz

- [Korea model]AC 220 V, 60 Hz

- Power consumption25 W

Standby power consumption

- MCR-040 0.5 W or less

MCR-140

- POWER SAVING: ECO 1.0 W or less

- POWER SAVING: NORMAL (default setting)

- 2.0 W or less

- Dimensions (W × H × D)..... 180 × 120 × 309 mm
(7 1/8 × 4 3/4 × 12 1/8 in)

- Weight3.6 kg (7.9 lbs.)

■ SPEAKER (NS-BP80)

- Driver unit 10 cm (4 in) full-range Cone type
/Non Magnetic Shielding Type

- Dimensions (W × H × D)..... 122 × 118 × 287 mm
(4 3/4 × 4 5/8 × 11 1/4 in)

- Weight 1.4 kg (3.1 lbs.)

■ TRANSMITTER (YIT-W11TX)

- Frequency2.4 GHz

- Transmission rangeApprox. 10 m (32.8 ft)
(without interference)

- Number of units which can be simultaneously transmitted to
.....Up to 7 units (depending on the circumstances)

The rating marking of “5 V \equiv 1.0 A” is marking for the charge to iPod.

Specifications are subject to change without notice.

iPod™

iPod is a trademark of Apple Inc., registered in the U.S. and other countries.

“Made for iPod” means that an electronic accessory has been designed to connect specifically to iPod and has been certified by the developer to meet Apple performance standards.

Apple is not responsible for the operation of this device or its compliance with safety and regulatory standards.



Digital Audio Broadcasting

This unit supports DAB tuning.

Limited Guarantee for European Economic Area (EEA) and Switzerland

Thank you for having chosen a Yamaha product. In the unlikely event that your Yamaha product needs guarantee service, please contact the dealer from whom it was purchased. If you experience any difficulty, please contact Yamaha representative office in your country. You can find full details on our website (<http://www.yamaha-hifi.com/> or <http://www.yamaha-uk.com/> for U.K. resident).

The product is guaranteed to be free from defects in workmanship or materials for a period of two years from the date of the original purchase. Yamaha undertakes, subject to the conditions listed below, to have the faulty product or any part(s) repaired, or replaced at Yamaha's discretion, without any charge for parts or labour. Yamaha reserves the right to replace a product with that of a similar kind and/or value and condition, where a model has been discontinued or is considered uneconomic to repair.

Conditions

1. The original invoice or sales receipt (showing date of purchase, product code and dealer's name) MUST accompany the defective product, along with a statement detailing the fault. In the absence of this clear proof of purchase, Yamaha reserves the right to refuse to provide free of charge service and the product may be returned at the customer's expense.
2. The product MUST have been purchased from an AUTHORISED Yamaha dealer within the European Economic Area (EEA) or Switzerland.
3. The product must not have been the subject of any modifications or alterations, unless authorised in writing by Yamaha.
4. The following are excluded from this guarantee:
 - a. Periodic maintenance and repair or replacement of parts due to normal wear and tear.
 - b. Damage resulting from:
 - (1) Repairs performed by the customer himself or by an unauthorised third party.
 - (2) Inadequate packaging or mishandling, when the product is in transit from the customer. Please note that it is the customer's responsibility to ensure the product is adequately packaged when returning the product for repair.
 - (3) Misuse, including but not limited to (a) failure to use the product for its normal purpose or in accordance with Yamaha's instructions on the proper use, maintenance and storage, and (b) installation or use of the product in a manner inconsistent with the technical or safety standards in force in the country where it is used.
 - (4) Accidents, lightning, water, fire, improper ventilation, battery leakage or any cause beyond Yamaha's control.
 - (5) Defects of the system into which this product is incorporated and/or incompatibility with third party products.
 - (6) Use of a product imported into the EEA and/or Switzerland, not by Yamaha, where that product does not conform to the technical or safety standards of the country of use and/or to the standard specification of a product sold by Yamaha in the EEA and/or Switzerland.
5. Where the guarantee differs between the country of purchase and the country of use of the product, the guarantee of the country of use shall apply.
6. Yamaha may not be held responsible for any losses or damages, whether direct, consequential or otherwise, save for the repair or replacement of the product.
7. Please backup any custom settings or data, as Yamaha may not be held responsible for any alteration or loss to such settings or data.
8. This guarantee does not affect the consumer's statutory rights under applicable national laws in force or the consumer's rights against the dealer arising from their sales/purchase contract.

Information for Users on Collection and Disposal of Old Equipment and Used Batteries



These symbols on the products, packaging, and/or accompanying documents mean that used electrical and electronic products and batteries should not be mixed with general household waste.

For proper treatment, recovery and recycling of old products and used batteries, please take them to applicable collection points, in accordance with your national legislation and the Directives 2002/96/EC and 2006/66/EC.



By disposing of these products and batteries correctly, you will help to save valuable resources and prevent any potential negative effects on human health and the environment which could otherwise arise from inappropriate waste handling.



For more information about collection and recycling of old products and batteries, please contact your local municipality, your waste disposal service or the point of sale where you purchased the items.

[Information on Disposal in other Countries outside the European Union]

These symbols are only valid in the European Union. If you wish to discard these items, please contact your local authorities or dealer and ask for the correct method of disposal.



Note for the battery symbol (bottom two symbol examples):

This symbol might be used in combination with a chemical symbol. In this case it complies with the requirement set by the Directive for the chemical involved.

Pb

CAUTION

Use of controls or adjustments or performance of procedures other than those specified herein may result in hazardous radiation exposure.

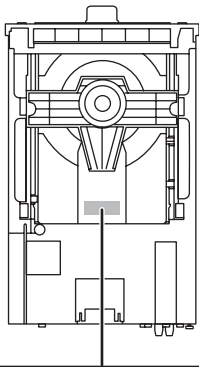
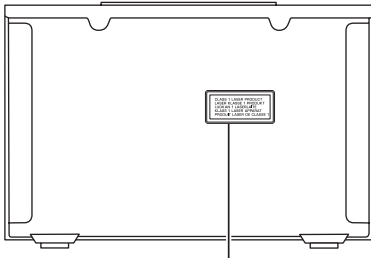

DANGER: AVOID DIRECT EXPOSURE TO THE BEAM
INVISIBLE LASER RADIATION WHEN OPEN

CAUTION: DO NOT STARE INTO BEAM
INVISIBLE LASER RADIATION WHEN OPEN

■ For U.K. customers

If the socket outlets in the home are not suitable for the plug supplied with this appliance, it should be cut off and an appropriate 3 pin plug fitted. For details, refer to the instructions described below.

Note

The plug severed from the mains lead must be destroyed, as a plug with bared flexible cord is hazardous if engaged in a live socket outlet.

■ Special Instructions for U.K. Model

IMPORTANT

THE WIRES IN MAINS LEAD ARE COLOURED IN ACCORDANCE WITH THE FOLLOWING CODE:

Blue: NEUTRAL

Brown: LIVE

As the colours of the wires in the mains lead of this apparatus may not correspond with the coloured markings identifying the terminals in your plug, proceed as follows:

The wire which is coloured BLUE must be connected to the terminal which is marked with the letter N or coloured BLACK. The wire which is coloured BROWN must be connected to the terminal which is marked with the letter L or coloured RED.

Make sure that neither core is connected to the earth terminal of the three pin plug.

